

1. Product description

Applications

The Grundfos Series 100 circulator pumps are specifically designed for heating systems. The pumps are also suitable for circulation of domestic hot water and for circulation of liquid in cooling and air-conditioning systems.

Heating systems

For central and district heating systems, use pump type UPS.

The UPS can be operated at three different speeds.

The pumps are used primarily for one- and two-pipe heating systems, but are, for example, also suitable for mixing loops in large systems.

For underfloor heating systems, we recommend using pump type UP(S) N, as the pumped liquid may often become aerated, causing an ordinary cast-iron pump housing to corrode.

Domestic hot-water systems

For circulation in domestic hot-water systems, use pump type GRUNDFOS UP N with stainless-steel pump housing.

The UP N can be connected to an on/off time switch to save energy. The on/off time switch can switch the pump on/off to limit pump operation to periods when hot water is usually required.

Cooling and air-conditioning systems

For cooling and air-conditioning systems, use standard UPS pumps or the special versions, types UPS K and UP KU, depending on type and size. See also [Product range](#) on page 7.

Temperature ranges: -25 to +95 °C
-25 to +110 °C.

These pumps are suitable for circulation of both cold and hot water.

Type key

Example	UP	S	D	40	-50	F
Type range						
S = electric speed control						
Twin-head pump						
Nominal diameter (DN) of suction and discharge ports [mm]						
Maximum head [dm]						
Pipe connection:						
= pipe thread (no letter)						
F = flange						
Pump housing:						
= cast iron (no letter)						
N = stainless steel						
A = pump housing with air separator, upward water flow						
K = cold-water version						
KU = cold-water version (foam-filled terminal box and stator)						



Fig. 1 One-pipe heating system

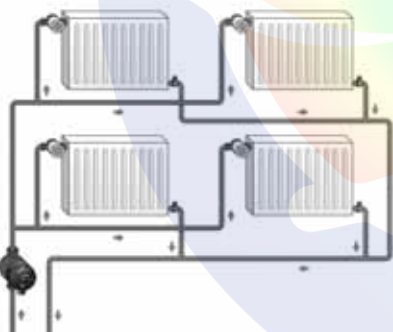

Fig. 2 Two-pipe heating system

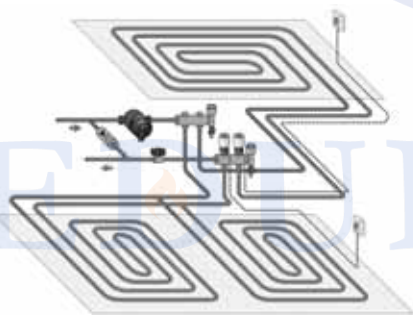
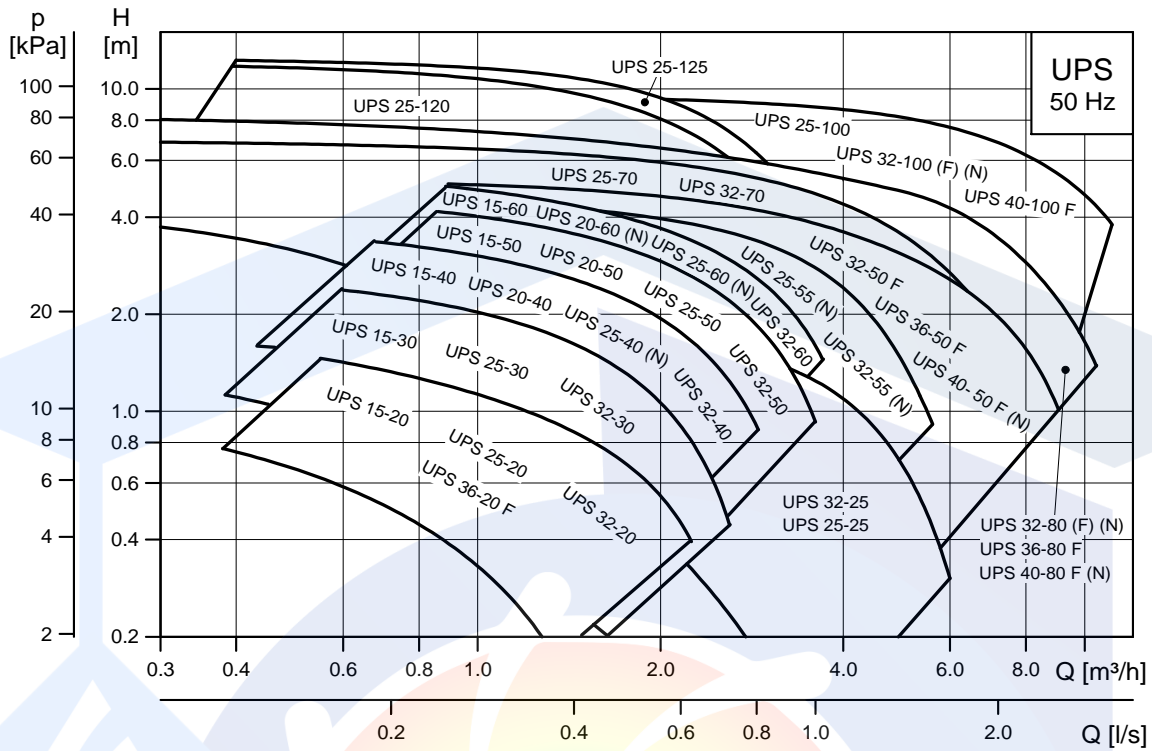

Fig. 3 Underfloor heating system

EDUPUMP.IR

Performance range



TM00 9602 1709

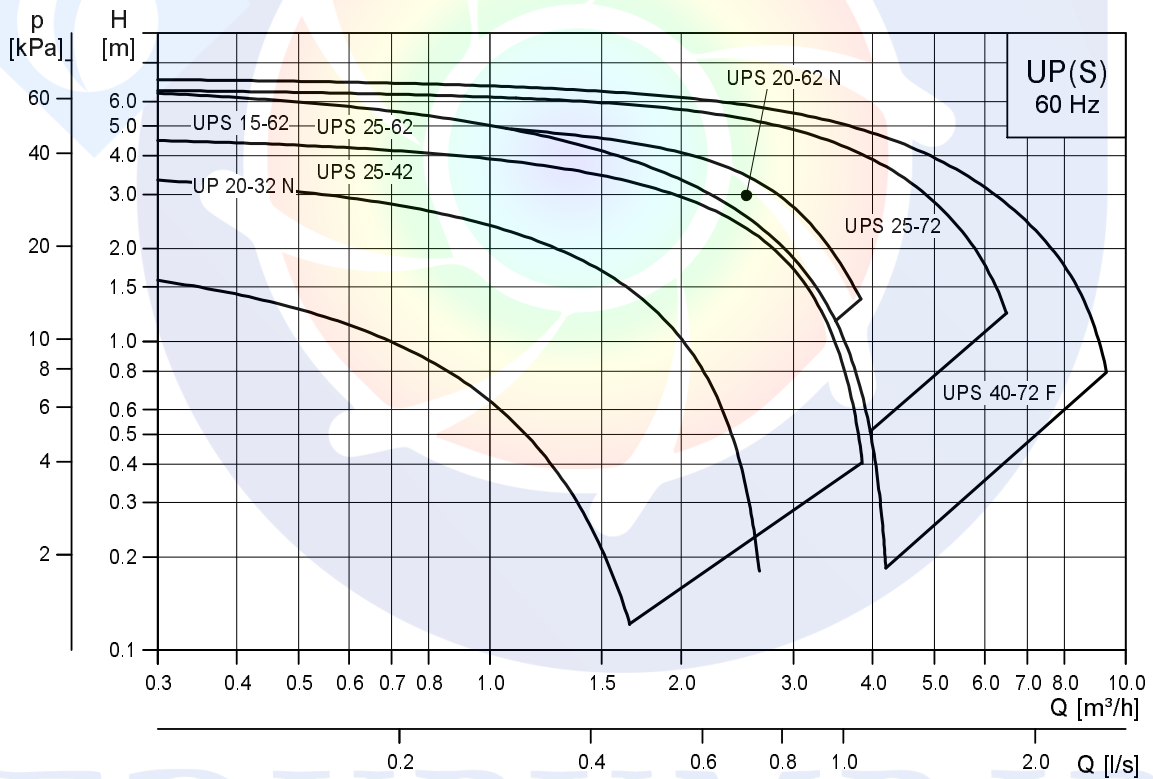

TM04 4621 1809

EDUPUMP.IR

4. Construction

The UP and UPS(D) pumps are of the canned-rotor type, i.e. pump and motor form an integral unit without shaft seal and with only two gaskets for sealing. The bearings are lubricated by the pumped liquid.

The pumps are characterised by the following:

- ceramic shaft and radial bearing
- carbon thrust bearing
- stainless-steel rotor can and bearing plate
- impeller of corrosion-resistant material
- pump housing of cast iron or stainless steel.

Motor

The motor is a 2- or 4-pole, asynchronous, squirrel-cage motor in conformity with the EMC directive.

Standards used: EN 61000-6-2 and EN 61000-6-3.

The terminal box is easily accessible and has functional cable connecting terminals. The cable entry is tight and incorporates cable relief.

The terminal box and the motor-pump unit have been wet-tested according to the Low Voltage Directive.

Standards used: EN 60335-1 and EN 60335-2-51.

The cable entry of single-phase motors can be pushed out of its guide to facilitate correct fitting of the cable.

Insulation class: F/H.

Cable connection: Pg 11 for 5.6 to 10 mm cable.

The motor incorporates thermal overload or impedance protection. Therefore, no external motor protection is required.

Sectional drawings

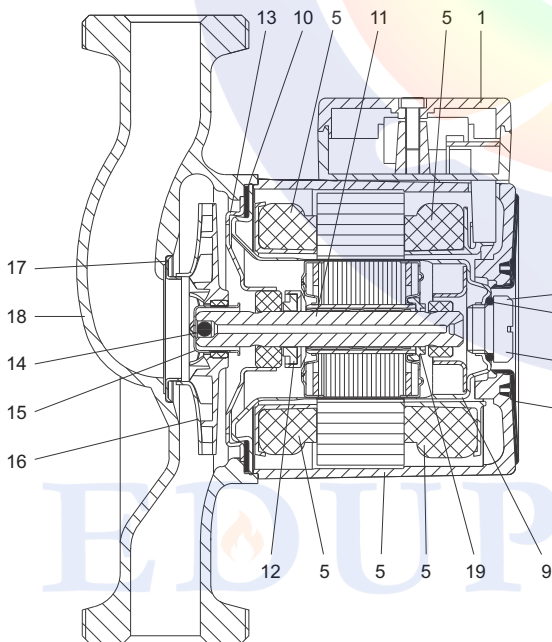

Fig. 4 Three-phase UP pump

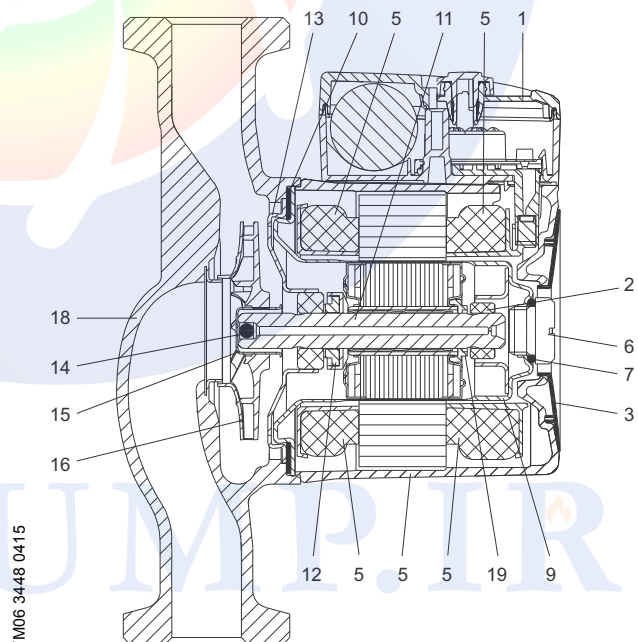

Fig. 5 Single-phase UP pump

Material specification

Pos.	Component	Material	EN	AISI
1	Terminal box	Composite, PPE/PS		
	• Terminal box cover	Composite, PPE/PS		
	• Electric unit (single-phase only)	Composite, PET		
2	Radial bearing	Ceramics		
3	Nameplate	Composite, PA66		
5	Stator housing	Aluminium, AlSi10Cu ₂		
	• Stator winding cap	Composite, PET		
	• Stator windings	Copper		
6	Air vent screw	Brass, nickel-plated, Ms58	2.0401.30	
7, 10	Gaskets	EPDM rubber		
9	Rotor can	Stainless steel	1.4301/1.4521	304
11	Shaft, complete	Ceramics		
		Stainless steel for UPS xx-100	1.4404	316L
12	Thrust bearing	Carbon		
	• Thrust bearing retainer	EPDM rubber		
13	Bearing plate	Stainless steel	1.4301	304
14	Ball (non-return valve)	EPDM rubber		
15	Split cone	Stainless steel	1.4301	304
16	Impeller	Composite, PES/PP 30 % GF		
17	Neck ring	Stainless steel	1.4301	304
		Cast iron	EN-JL1020 EN-JL1030	A48-25B A48-30B
		Stainless steel	1.4301	304
		Stainless steel	1.4308	CF8
18	Pump housing	Composite, PES		
		Composite		
		EPDM rubber		
19	Stop ring	Composite, PES		
	Non-return valve casing (twin-head pump)	Composite		
	Valve flap (twin-head pump)	EPDM rubber		
20	Intermediate ring	Stainless steel	1.4301	304

EDUPUMP.IR

UPS 32-80 (N)

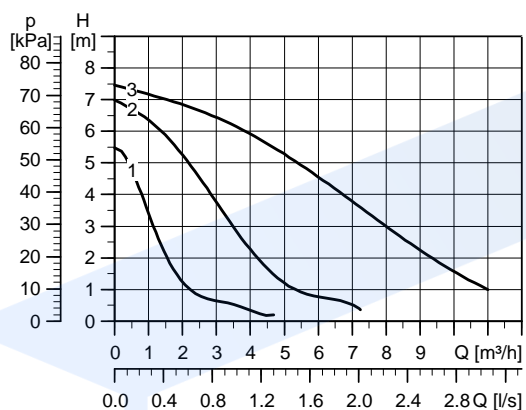

TM04 3761 2409

Electrical data 1 x 230 V, 50 Hz

Speed	P1 [W]	I _{1/1} [A]
3	220	0.98
2	200	0.90
1	135	0.60

Dimensions

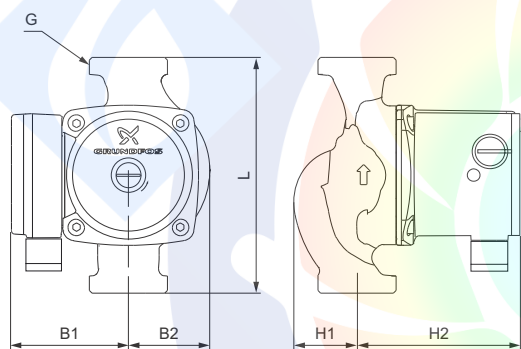

TM06 5360 4515

Connections: See [Pipe connections](#), page 85.
 System pressure: Max. 10 bar
 Liquid temperature: -25 to +110 °C (TF 110)
 Also available with: Stainless-steel pump housing, type N (only UPS 32-80 180)

Pump type	Dimensions [mm]						Weights [kg]		Shipping volume [m ³]
	L	H1	H2	B1	B2	G	Net	Gross	
UPS 32-80	180	48	121	82	62	2"	4.6	5.0	0.008
UPS 32-80 N*	180	48	121	82	62	2"	4.9	5.2	0.008

* This circulator is suitable for drinking water only.

EDUPUMP.IR



EDUPUMP
WWW.EDUPUMP.IR

اولین و بزرگترین

سایت تخصصی سیستم‌های پمپاژ
با امکان محاسبه آنلاین و انتخاب پمپ

تولید بوستر پمپ آتش نشانی

در کلاس‌های S3 - S2 - S1
مورد تایید سازمان آتش نشانی تهران



اولین و بزرگترین مرجع انتخاب آنلاین سیستم‌های پمپاژ

انتخاب آنلاین انواع بوستر پمپ

انتخاب آنلاین انواع پمپ

ارائه مطالب تخصصی

اولین سایت مرجع

انتخاب آنلاین پمپ

در حوزه‌های:

ایمنی و آتش نشانی
آب و فاضلاب
صنایع غذایی
استخر
صنعت
معدن



تولید بوستر پمپ

آبرسانی دور متغیر

بدون محدودیت برند



آموزش

تهویه و تخلیه دود
سیستم‌های پمپاژ
ایمنی معماری
اطفاء حریق
اعلام حریق

مشاوره - طراحی - اجراء

تاسیسات مکانیکی (موتورخانه - استخر)
تهویه و تخلیه دود
سیستم‌های پمپاژ
ایمنی معماری
اعلام حریق
اطفاء حریق

تهران، سعدی شمالی، خیابان مرادی نور، پلاک ۳۱

تلفن: ۰۲۱-۷۷۶۸۶۹۶۶ فکس: ۰۲۱-۷۷۶۷۸۶۵۹

EDUPUMP.IR

WWW.EDUPUMP.IR