

7. TP Series 300 pumps



Fig. 12 TP Series 300

Technical data

	PN 16 version	PN 25 version
Flow rate [m ³ /h]	Up to 2000	Up to 4500
Head [m]	Up to 93	Up to 140
Liquid temperature [°C]	-25 to +140	-40 to +150*
Maximum operating pressure [bar]	16	25
Direction of rotation	Clockwise	

* At 120 to 150 °C, the maximum operating pressure is less than 23 bar.

Construction

Grundfos TP, TPD Series 300 pumps are single-stage, close-coupled pumps with in-line inlet and outlet ports of identical diameter.

The pumps are fitted with a fan-cooled asynchronous motor. Motor and pump shafts are connected via a rigid sleeve coupling.

Most TP Series 300 pumps are available as single-head, TP, and twin-head, TPD pumps.

TP Series 300 pumps have PN 16 flanges or PN 25 flanges.

The largest pumps have DN 500, PN 40 inlet flanges and DN 400, PN 40 outlet flanges and a maximum operating pressure of 25 bar.

The pumps are fitted with an unbalanced or a balanced mechanical shaft seal.

The pumps are of the top-pull-out design, that is you can remove the power head (motor, pump head and/or motor stool and impeller) for maintenance or service while the pump housing remains in the pipes.

The pump housing is provided with a replaceable wear ring to ensure high pump efficiency for life.

The twin-head pumps are designed with two parallel power heads. A non-return flap valve in the common outlet port is opened by the flow of the pumped liquid and prevents backflow of liquid into the idle pump head.

As radial and axial forces are absorbed by the fixed bearing in the motor drive-end, the pump requires no bearing.

The impeller is hydraulically balanced to minimise axial forces.

TP, TPD Series 300 pumps are fitted with high-efficiency motors.

TP Series 300 pumps with bronze impeller are suitable for pumping brine.

EDUPUMP.IR

1. Pump data

Introduction

TP pumps are designed for applications such as:

- district heating systems
- heating systems
- air-conditioning systems
- district cooling systems
- water supply
- industrial processes
- industrial cooling.

The pumps are available with either mains-operated motors (TP and TPD) or electronically speed-controlled motors (TPE, TPED, TPE2, TPE2 D, TPE3, TPE3 D).

The pumps are all single-stage, in-line centrifugal pumps with mechanical shaft seal. The pumps are of the close-coupled type, that is the pump and the motor are separate units.

TP, mains-operated pumps

The TP range is divided into three groups based on their construction: TP Series 100, 200 and 300.

TP Series 100 with union or flange connection

Rp 1 (DN 25) to Rp 1 1/4 (DN 32) and motor sizes from 0.12 to 0.25 kW.

For further information, see page 27.

TP Series 200 with flange connection

DN 32 to DN 100 and motor sizes from 0.12 to 2.2 kW.

For further information, see page 27.

TP Series 300 with flange connection

We offer two versions:

- 16-bar version with DN 32 to DN 350 flanges and motor sizes from 0.25 to 315 kW
- 25-bar version with DN 100 to DN 400 flanges and motor sizes from 5 to 630 kW.

For further information, see page 29.

TPE, TPE2 and TPE3 speed-controlled pumps

We offer the following speed-controlled pumps which are based on the construction and choice of material of the TP pumps:

- TPE Series 1000 pumps without factory-fitted differential-pressure sensor.
- TPE Series 2000 pumps with factory-fitted differential-pressure sensor.
- TPE2 pumps without built-in differential-pressure sensor and temperature sensor.
- TPE3 pumps with built-in differential-pressure sensor and temperature sensor.

All pumps with 2-pole motors up to 11 kW and 4-pole motors up to 7.5 kW are fitted with Grundfos permanent-magnet MGE motors with motor efficiency class IE5 according to IEC 60034-30-2.

TPE Series 1000 pumps

The motors have a built-in frequency converter.

Via an external signal from a sensor or a controller, the pumps allow for any configuration and control method required, that is constant pressure, temperature or flow.

For further information, see page 32.

TPE Series 2000 pumps

The pumps have a factory-fitted differential-pressure sensor.

The pumps are factory-set to proportional-pressure control.

The motors have a built-in frequency converter for continuous adjustment of the pressure to the flow rate.

The range is recognised as a preset solution for quick and safe installation. Pumps fitted with 2-pole motors below 15 kW and 4-pole motors below 11 kW have a colour display for easy and intuitive pump setup and with full access to all functions.



Fig. 1 Example of main display on a TPE Series 2000 with advanced control panel

For further information, see page 35.

TM05 8893 2813

EDUPUMP.IR

Performance range, 2-pole, PN 6, 10, 16

See page 174 for performance curves.

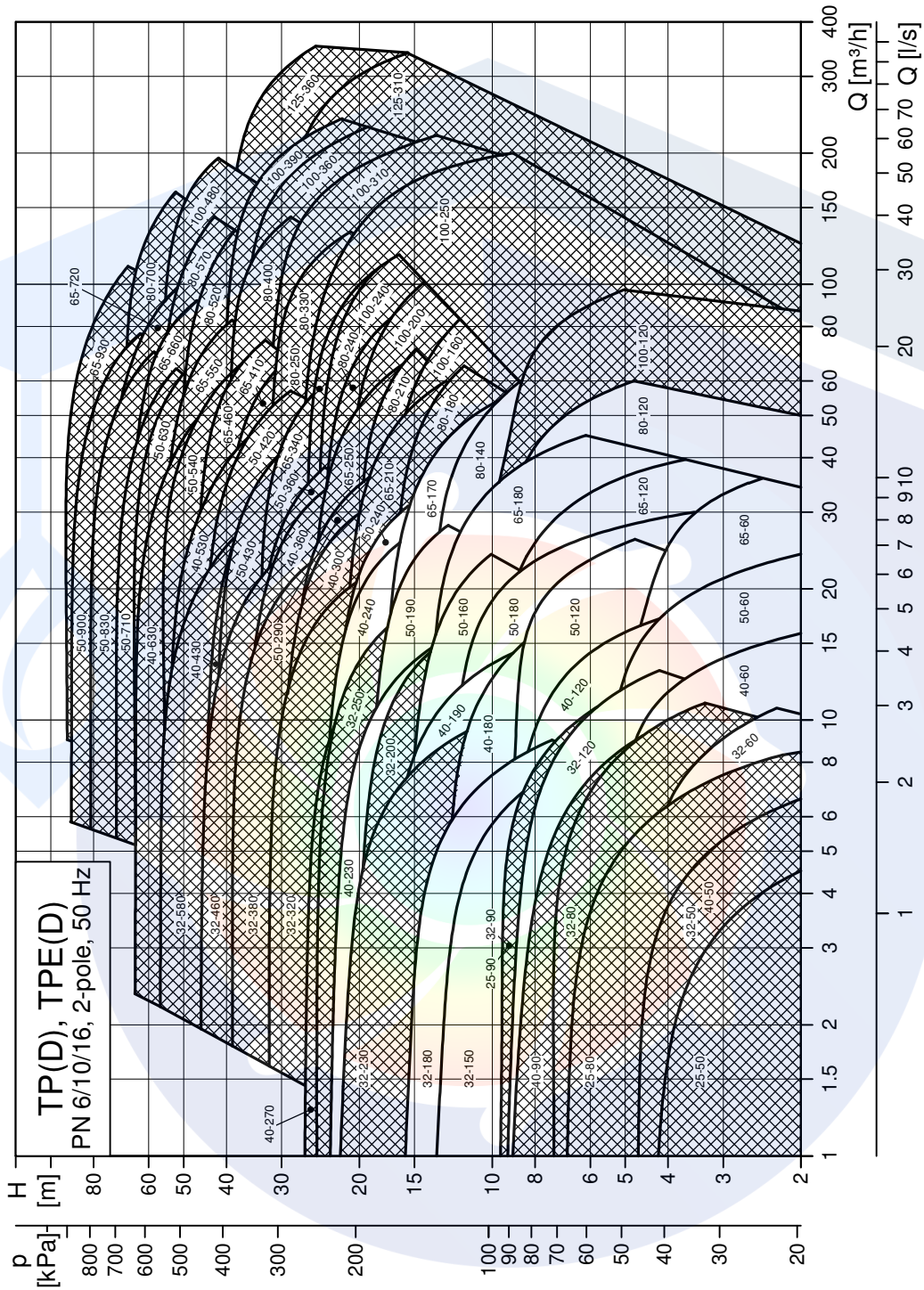

Note: All QH curves apply to single-head pumps. For further information about curve conditions, see page 160. The hatched area shows the performance range of TPE pumps.

EDUPUMP.IR

TM02 7550 2218

Materials

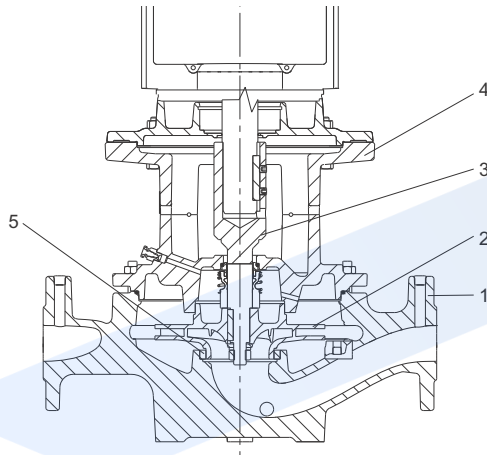

TM04 9586 2115

Fig. 13 Sectional drawing of TP Series 300

Material specification

TP Series 300, PN 16

Pos.	Component	Material	EN/DIN
1	Pump housing	Cast iron EN-GJL-250	EN-JL 1040
2	Impeller	Cast iron EN-GJL-200, bronze CuSn10	EN-JL 1030 2.1093
3	Stub shaft	Stainless steel	1.4301
	Two-part stub shaft	Stainless steel/steel	1.4301/1.0301
4	Pump head/motor stool	Cast iron EN-GJL-250	EN-JL 1040
	Secondary seals	EPDM	
	Rotating seal face	Metal-impregnated carbon Silicon carbide	
	Stationary seat	Silicon carbide	
5	Wear ring	Bronze CuSn10/brass CuZn34Mn3Al2Fe1-C	2.1093

TP Series 300, PN 25

Pos.	Component	Material	EN/DIN
1	Pump housing	Ductile cast iron EN-GJS-400-18-LT	EN-JS 1025
2	Impeller	Cast iron EN-GJL-200, bronze CuSn10	EN-JL 1030 2.1093
3	Stub shaft	Stainless steel	1.4301
	Two-part stub shaft	Stainless steel/steel	1.4301/1.0301
4	Motor stool	Cast iron EN-GJL-250	EN-JL 1040
	Secondary seals	EPDM FXM	
	Rotating seal face	Metal-impregnated carbon Silicon carbide	
	Stationary seat	Silicon carbide	
5	Wear ring	Bronze CuSn10/brass CuZn34Mn3Al2Fe1-C	2.1093

TP Series 300, DN 400, PN 25

Pos.	Component	Material	EN/DIN
1	Pump housing	Ductile cast iron EN-GJS-400-18 (A-LT)	EN-JS1020
2	Impeller	Ductile cast iron EN-GJS-400 Bronze CuSn10	EN-JS1030 2.1093
3	Pump shaft	Stainless steel	1.4436
4	Coupling	Cast iron EN-GJL-250	EN-JL 1040
5	Motor stool	Cast iron EN-GJL-250	EN-JL 1040
	Secondary seals	EPDM rubber	
	Rotating seal face	Resin-impregnated carbon	
	Stationary seat	Tungsten carbide	

Mechanical shaft seal

For 16-bar versions, the following types of unbalanced mechanical shaft seals are available as standard:

- **BAQE**
The BAQE shaft seal is a rubber bellows seal with carbon/silicon carbide seal faces and secondary seals of EPDM.
- **BQQE**
The BQQE shaft seal is a rubber bellows seal with silicon carbide/silicon carbide seal faces and secondary seals of EPDM.

For 25-bar versions, the following types of balanced mechanical shaft seals are available as standard:

- **DAQF**
The DAQF shaft seal is a balanced O-ring seal with carbon/silicon carbide seal faces and secondary seals of FXM.
- **DQQE**
The DQQE shaft seal is a balanced O-ring seal with silicon carbide/silicon carbide seal faces and secondary seals of EPDM.
- **DBUE**
The DBUE shaft seal is a balanced O-ring seal with carbon/tungsten carbide seal faces and secondary seals of EPDM.

For further information about common pumped liquids with recommended shaft seals, see page 24.

Special shaft seals are available for partly conditioned water or other liquids containing abrasive or crystallising particles. See page 24.

Connections

TP Series 300 pumps have PN 16 or PN 25 flanges. All dimensions are according to ISO 7005-2 or EN 1092-2.

EDUPUMP.IR

TP 80-XX/2

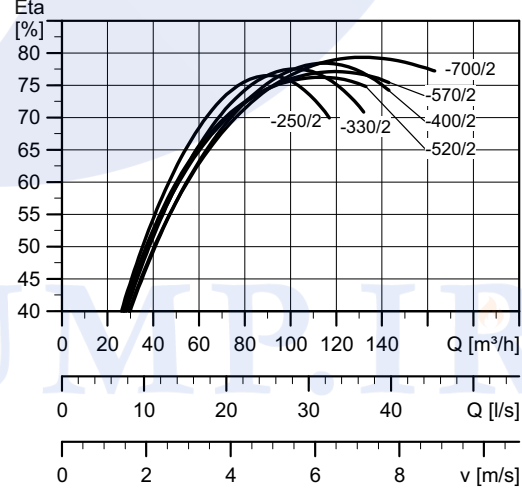
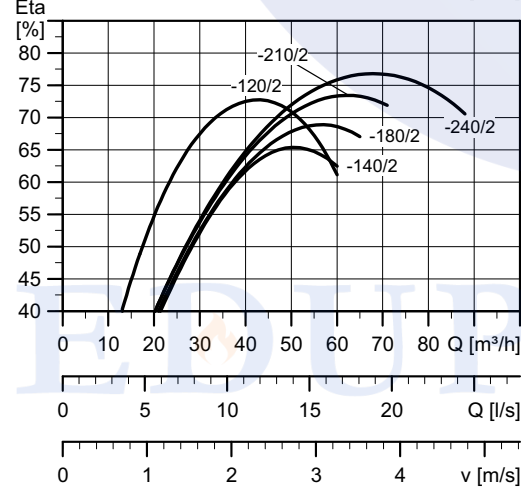
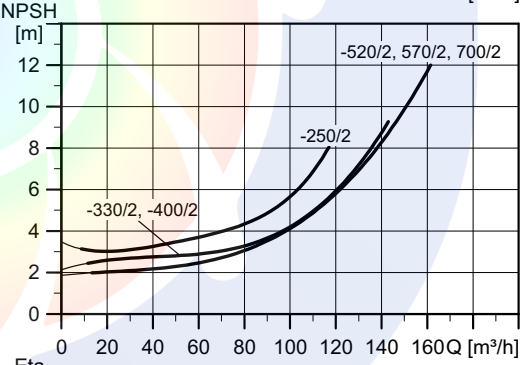
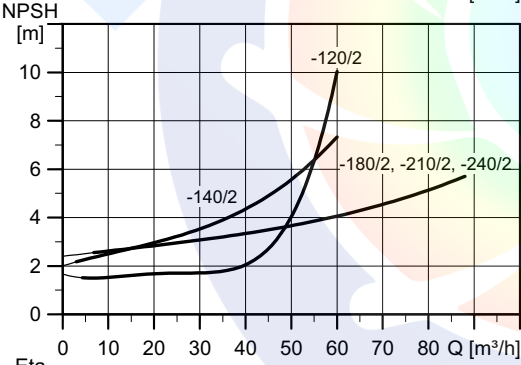
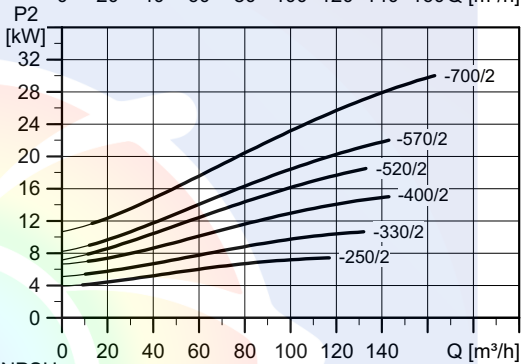
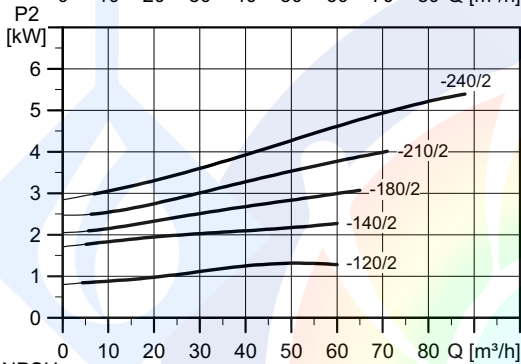
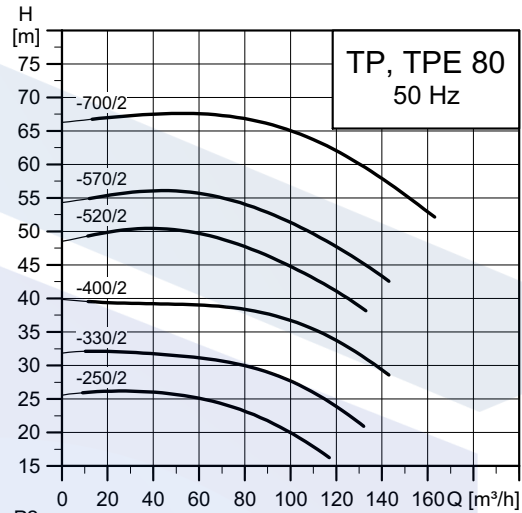
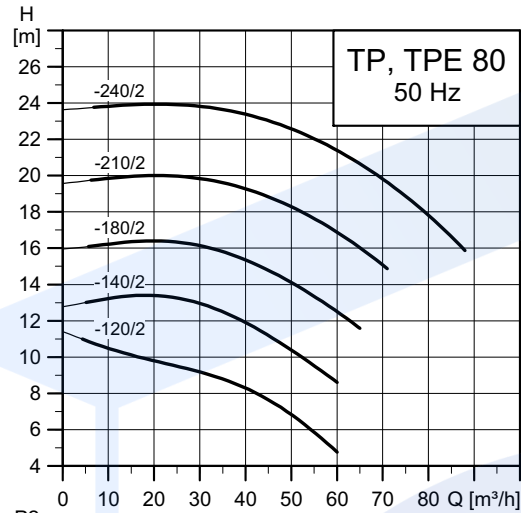

Note: All curves apply to single-head pumps. For further information, see page 160.

TM02 5025 2115

TM02 8750 2115

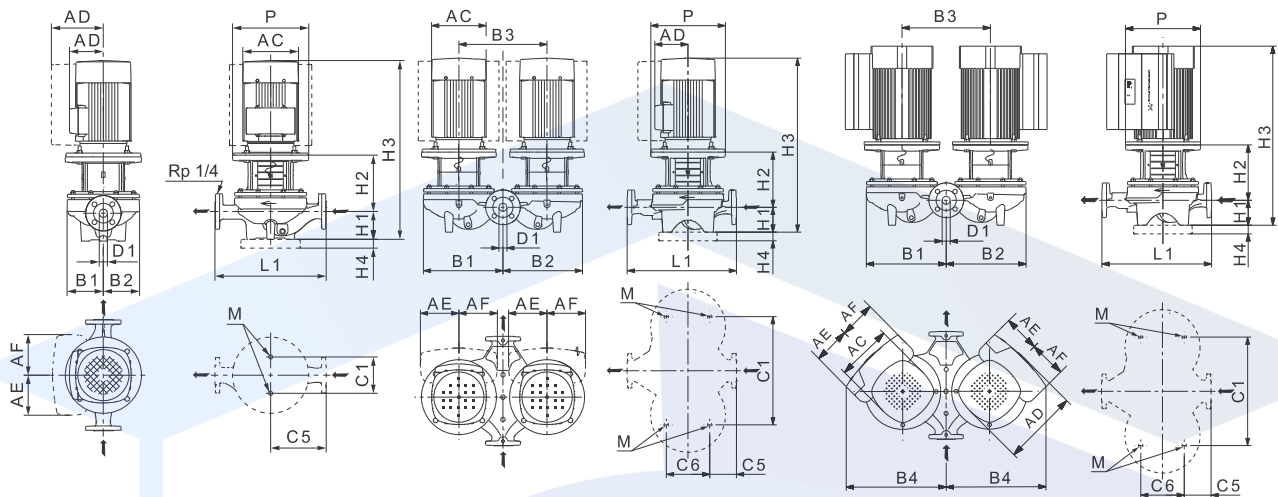

TM02 8632 2614 - TM02 8631 2614 - TM06 2653 4614

Technical data

TP 80	-120/2	-140/2	-180/2	-210/2	-240/2	-250/2	-330/2	-400/2	-520/2	-570/2	-700/2
TPD	•	•	•	•	•	•	•	•	•	•	•
TPE	-	-	•	•	•	•	•	•	•	•	•***
TPED	-	-	•	•	•	•	•	•	•	•	-
Series	200	300	300	300	300	300	300	300	300	300	300
IEC size	1~ TP	90	-	-	-	-	-	-	-	-	-
	3~ TP	90	90	100	112	132	132	160	160	160	180
	1~ TPE	-	-	-	-	-	-	-	-	-	-
	3~ TPE	-	-	100	112	132	132	160	160	160	180
P2	1~/3~ TP ★ [kW]	1.5/1.5	-/2.2	-/3	-/4	-/5.5	-/7.5	-/11	-/15	-/18.5	-/22
	1~/3~ TPE [kW]	-	-	-/3	-/4	-/5.5	-/7.5	-/11	-/15	-/18.5	-/22
PN	PN 6/10	PN 16	PN 16	PN 16	PN 16	PN 16	PN 16	PN 16	PN 16	PN 16	PN 16
T _{min} , T _{max}	[°C]	[-25;140]	[-25;120]	[-25;120]	[-25;120]	[-25;120]	[-25;120]	[-25;120]	[-25;120]	[-25;120]	[-25;120]
D1	[mm]	80	80	80	80	80	80	80	80	80	80
AC	1~/3~ TP [mm]	178/178	-/178	-/198	-/220	-/220	-/260	-/314	-/314	-/314	-/402
	1~/3~ TPE [mm]	-	-	-/191	-/191	-/191	-/255	-/255	-/314	-/314	-/402
AD	1~/3~ TP [mm]	139/139	-/110	-/120	-/134	-/134	-/159	-/204	-/204	-/204	-/315
	1~/3~ TPE [mm]	-	-	-/201	-/201	-/201	-/237	-/237	-/308	-/308	-/470
AE	1~/3~ TPE [mm]	-	-	-/146	-/146	-/146	-/173	-/173	-/210	-/210	-/126
AF	1~/3~ TPE [mm]	-	-	-/146	-/146	-/146	-/173	-/173	-/210	-/210	-/126
P	[mm]	135	200	250	250	300	300	350	350	350	400
B1 ★★	[mm]	120/134	125/296	125/296	125/296	125/296	176/366	176/366	176/366	187/416	187/416
B2 ★★	[mm]	100/225	119/290	119/290	119/290	119/290	144/354	144/354	144/354	162/405	162/405
B3	[mm]	240	340	340	340	340	400	400	400	470	470
B4 ★★	[mm]	-	-	-/416	-/416	-/416	-/491	-/491	-/538	-/573	-/573
C1 ★★	[mm]	160/240	144/420	144/420	144/420	144/420	144/480	144/480	144/480	144/550	144/550
C5 ★★	[mm]	180/53	180/78	180/78	180/78	180/78	220/93	220/93	220/93	250/133	250/133
C6	[mm]	173	175	175	175	175	175	175	175	350	350
L1	[mm]	360	360	360	360	360	440	440	440	500	500
H1	[mm]	97	105	105	105	105	115	115	115	115	115
H2	[mm]	163	176	204	204	243	243	273	273	273	273
H3	1~/3~ TP [mm]	581/581	-/602	-/644	-/681	-/739	-/737	-/859	-/859	-/903	-/999
	1~/3~ TPE [mm]	-	-	-/643	-/643	-/713	-/747	-/794	-/859	-/903	-/929
H4	[mm]	-	-	-	-	-	-	35	35	35	35
M		M16	M16	M16	M16	M16	M16	M16	M16	M16	M16

★ TP, TPD pumps are primarily fitted with IE3 motors. See *Motor data* on page 125.

★★ The dimension before the slash applies to the single-head pump, and the dimension after the slash applies to the twin-head pump.

★★★ The integrated CUE can be positioned in an angle deviating from this drawing with up to 30 degrees. For further information look in Grundfos Product Center.



EDUPUMP
WWW.EDUPUMP.IR

اولین و بزرگترین

سایت تخصصی سیستم‌های پمپاژ
با امکان محاسبه آنلاین و انتخاب پمپ

تولید بوستر پمپ آتش نشانی

در کلاس‌های S3 - S2 - S1
مورد تایید سازمان آتش نشانی تهران



اولین و بزرگترین مرجع انتخاب آنلاین سیستم‌های پمپاژ

انتخاب آنلاین انواع بوستر پمپ

انتخاب آنلاین انواع پمپ

ارائه مطالب تخصصی

اولین سایت مرجع

انتخاب آنلاین پمپ

در حوزه‌های:

ایمنی و آتش نشانی
آب و فاضلاب
صنایع غذایی
استخر
صنعت
معدن



تولید بوستر پمپ

آبرسانی دور متغیر

بدون محدودیت برند



آموزش

تهویه و تخلیه دود
سیستم‌های پمپاژ
ایمنی معماری
اطفاء حریق
اعلام حریق

مشاوره - طراحی - اجراء

تاسیسات مکانیکی (موتورخانه - استخر)
تهویه و تخلیه دود
سیستم‌های پمپاژ
ایمنی معماری
اعلام حریق
اطفاء حریق

تهران، سعدی شمالی، خیابان مرادی نور، پلاک ۳۱

تلفن: ۰۲۱-۷۷۶۸۶۹۶۶ فکس: ۰۲۱-۷۷۶۷۸۶۵۹

EDUPUMP.IR

WWW.EDUPUMP.IR