

## 6. TP Series 100 and 200 pumps



Fig. 9 TP Series 100 and TP Series 200

### Technical data

Flow rate:	Up to 90 m <sup>3</sup> /h
Head:	Up to 27 m
Liquid temperature, TP Series 100:	-25 to +120 °C
Liquid temperature, TP Series 200:	-25 to +140 °C
Maximum operating pressure:	Up to 16 bar
Direction of rotation:	Counterclockwise

### Construction

Grundfos TP Series 100 and Series 200 pumps are single-stage, close-coupled pumps with in-line inlet and outlet ports of identical diameter.

The pumps are fitted with a fan-cooled asynchronous motor. Motor and pump shafts are connected via a rigid two-part coupling.

TP Series 100 pumps with union connection are available as single-head, TP, pumps.

TP Series 200 pumps are available as single-head, TP, and twin-head, TPD, pumps.

TP Series 200 pumps have PN 6 or PN 10 flanges.

The pumps are fitted with an unbalanced mechanical shaft seal.

The pumps are of the top-pull-out design, that is you can remove the power head (motor, pump head and impeller) for maintenance or service while the pump housing remains in the pipes.

The twin-head pumps are designed with two parallel power heads. A flap valve in the common outlet port is opened by the flow of the pumped liquid and prevents backflow of liquid into the idle pump head.

As radial and axial forces are absorbed by the fixed bearing in the motor drive-end, the pump requires no bearing.

The pumps are fitted with high-efficiency motors.

Pumps with a bronze or stainless-steel pump housing are suitable for circulation of domestic hot water.

### Materials

#### TP Series 100

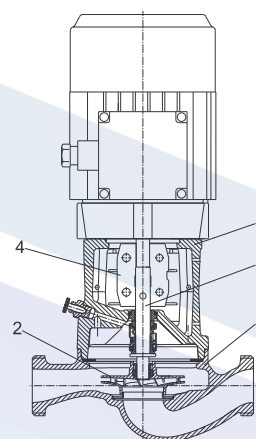

Fig. 10 Sectional drawing of TP Series 100 with union connection

#### Material specification, Series 100

Pos.	Component	Material	EN/DIN
1	Pump housing	Cast iron EN-GJL-150, EN-GJL-200, stainless steel	EN-JL 1020 EN-JL 1030 1.4308
2	Impeller	Composite PES/PP 30 % GF	
3	Shaft	Stainless steel	1.4057
4	Coupling	Cast iron EN-GJL-400	0.7040
5	Pump head	Cast iron EN-GJL-200, stainless steel	EN-JL 1030 1.4308
	Secondary seals	EPDM	
	Rotating seal face	Silicon carbide	
	Stationary seat	Carbon (resin-impregnated), silicon carbide	

EDUPUMP.IR

## 1. Pump data

### Introduction

TP pumps are designed for applications such as:

- district heating systems
- heating systems
- air-conditioning systems
- district cooling systems
- water supply
- industrial processes
- industrial cooling.

The pumps are available with either mains-operated motors (TP and TPD) or electronically speed-controlled motors (TPE, TPED, TPE2, TPE2 D, TPE3, TPE3 D).

The pumps are all single-stage, in-line centrifugal pumps with mechanical shaft seal. The pumps are of the close-coupled type, that is the pump and the motor are separate units.

### TP, mains-operated pumps

The TP range is divided into three groups based on their construction: TP Series 100, 200 and 300.

#### TP Series 100 with union or flange connection

Rp 1 (DN 25) to Rp 1 1/4 (DN 32) and motor sizes from 0.12 to 0.25 kW.

For further information, see page 27.

#### TP Series 200 with flange connection

DN 32 to DN 100 and motor sizes from 0.12 to 2.2 kW.

For further information, see page 27.

#### TP Series 300 with flange connection

We offer two versions:

- 16-bar version with DN 32 to DN 350 flanges and motor sizes from 0.25 to 315 kW
- 25-bar version with DN 100 to DN 400 flanges and motor sizes from 5 to 630 kW.

For further information, see page 29.

### TPE, TPE2 and TPE3 speed-controlled pumps

We offer the following speed-controlled pumps which are based on the construction and choice of material of the TP pumps:

- TPE Series 1000 pumps without factory-fitted differential-pressure sensor.
- TPE Series 2000 pumps with factory-fitted differential-pressure sensor.
- TPE2 pumps without built-in differential-pressure sensor and temperature sensor.
- TPE3 pumps with built-in differential-pressure sensor and temperature sensor.

All pumps with 2-pole motors up to 11 kW and 4-pole motors up to 7.5 kW are fitted with Grundfos permanent-magnet MGE motors with motor efficiency class IE5 according to IEC 60034-30-2.

#### TPE Series 1000 pumps

The motors have a built-in frequency converter.

Via an external signal from a sensor or a controller, the pumps allow for any configuration and control method required, that is constant pressure, temperature or flow.

For further information, see page 32.

#### TPE Series 2000 pumps

The pumps have a factory-fitted differential-pressure sensor.

The pumps are factory-set to proportional-pressure control.

The motors have a built-in frequency converter for continuous adjustment of the pressure to the flow rate.

The range is recognised as a preset solution for quick and safe installation. Pumps fitted with 2-pole motors below 15 kW and 4-pole motors below 11 kW have a colour display for easy and intuitive pump setup and with full access to all functions.



Fig. 1 Example of main display on a TPE Series 2000 with advanced control panel

For further information, see page 35.

TM05 8893 2813

EDUPUMP.IR

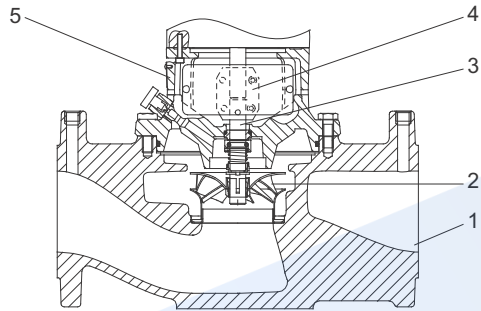

**TP Series 200**

TM03 1211 4715

**Fig. 11** Sectional drawing of TP Series 200 with flange connection

**Material specification, Series 200**

Pos.	Component	Material	EN/DIN
1	Pump housing	Cast iron EN-GJL-250, bronze CuSn10	EN-JL 1040 2.1093
2	Impeller	Stainless steel	1.4301
3	Shaft	Stainless steel	1.4305
4	Coupling	Cast iron EN-GJL-400	0.7040
5	Pump head	Cast iron EN-GJL-250, bronze	0.6025 2.1093
	Secondary seals	EPDM	
	Rotating seal face	Silicon carbide	
	Stationary seat	Carbon (resin-impregnated), silicon carbide	

**Mechanical shaft seal**

Two types of unbalanced mechanical shaft seal are available as standard:

- **BQBE**

The BQBE shaft seal is a rubber bellows seal with silicon carbide/carbon seal faces and secondary seals of EPDM.

- **BQQE**

The BQQE shaft seal is a rubber bellows seal with silicon carbide/silicon carbide seal faces and secondary seals of EPDM.

For more information about common pumped liquids with recommended shaft seals, see page 24.

**Shaft seal specification**

Unbalanced shaft seal	TP Series 100	Version KU according to EN 12756
	TP, TPD Series 200	Version NU according to EN 12756
Shaft diameter	12 and 16 mm	
Rubber bellows	EPDM	
Seal faces	Silicon carbide/carbon	
	Silicon carbide/silicon carbide	

Special shaft seals are available for partly conditioned water or other liquids containing abrasive or crystallising particles. See page 24.

**Connections**

TP Series 100 pumps with union connection have inlet and outlet union threads to ISO 228-1.

TP Series 200 pumps up to DN 65 are fitted with combination flanges PN 6 / PN 10. DN 80 or DN 100 pumps have either PN 6 or PN 10 flanges. You can connect all flanges to flanges in accordance with EN 1092-2 and ISO 7005-2.

**Features and benefits**

TP Series 100 and Series 200 pumps have these features and benefits:

**Optimised hydraulics for high efficiency**

- Reduced power consumption.

**High-efficiency motors**

- TP pumps are fitted with high-efficiency motors. High-efficiency motors offer reduced energy consumption. TP pumps are primarily fitted with motors that meet the legislative requirements of the EuP IE3 grade. For further information, see *Motors*, pages 125 to 130.

**Top-pull-out design**

- Easy dismantling in case of service.

**In-line design**

- Contrary to end-suction pumps, in-line pumps allow straight pipes and thus often reduce installation costs.

**Pump housing and pump head are electrocoated to improve the corrosion resistance**

- Electrocoating includes:
  1. Alkaline cleaning.
  2. Pretreatment with zinc phosphate coating.
  3. Cathodic electrocoating, epoxy.
  4. Curing of paint film at 200 to 250 °C.

For low-temperature applications at a high humidity, Grundfos offers TP pumps with extra surface treatment to avoid corrosion. These pumps are available on request.

**Stainless-steel impeller and neck ring**

- Wear-free operation with high efficiency.

EDUPUMP.IR



TP 100-XX/2

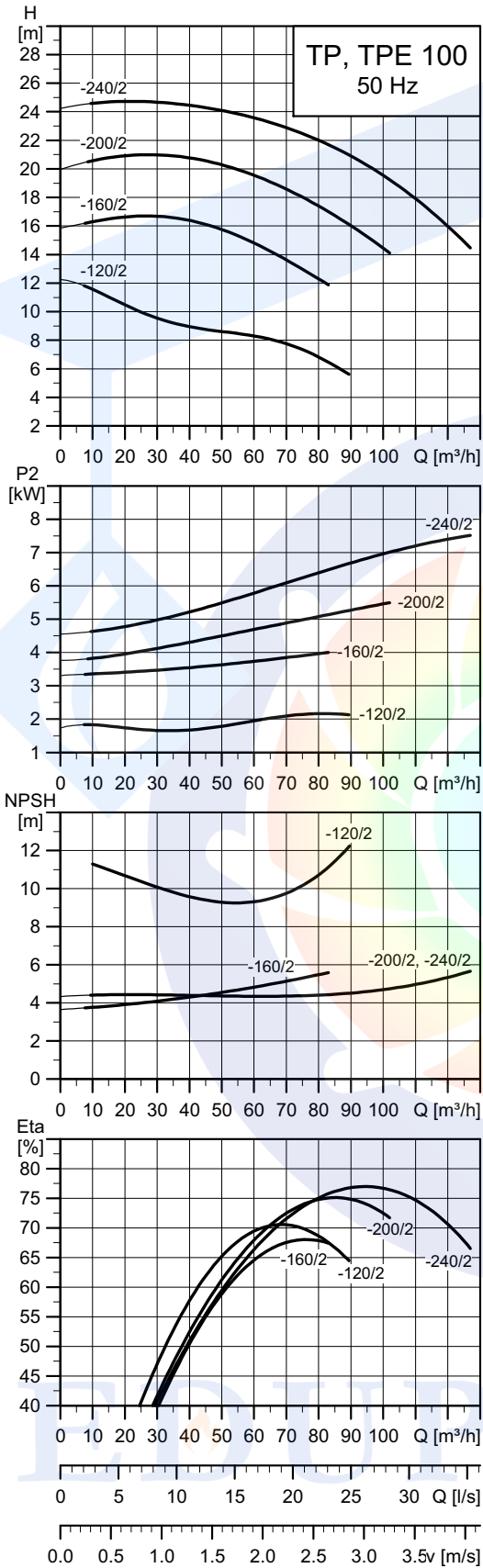

TM02 5026 4715

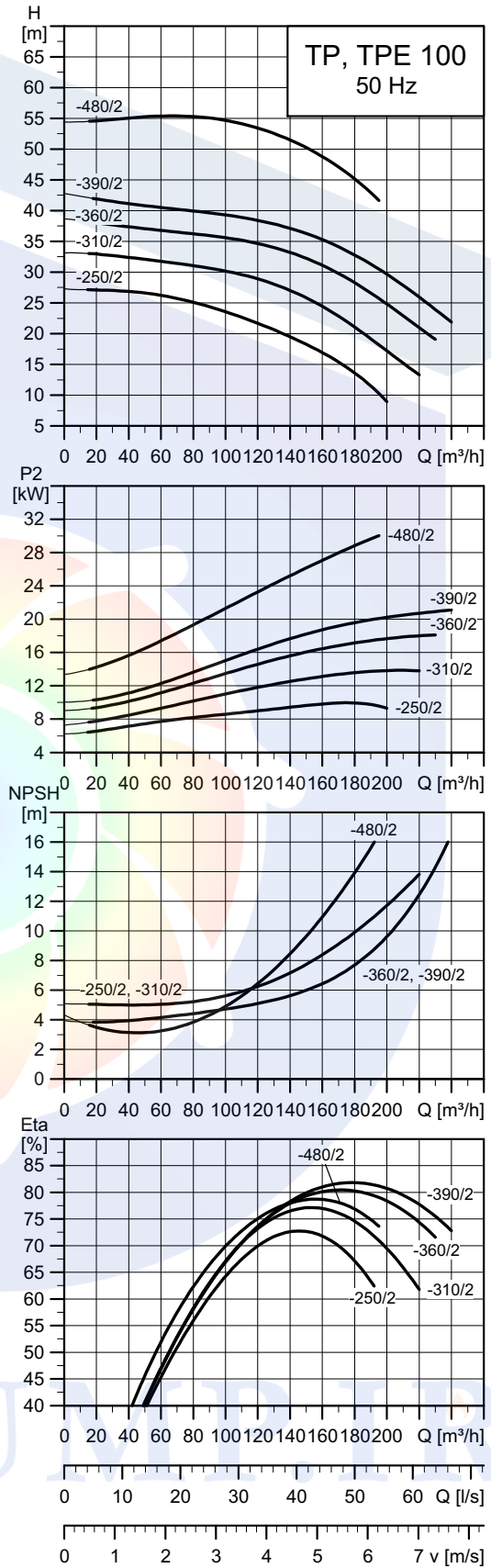

TM02 8751 2115

Note: All curves apply to single-head pumps. For further information, see page 160.

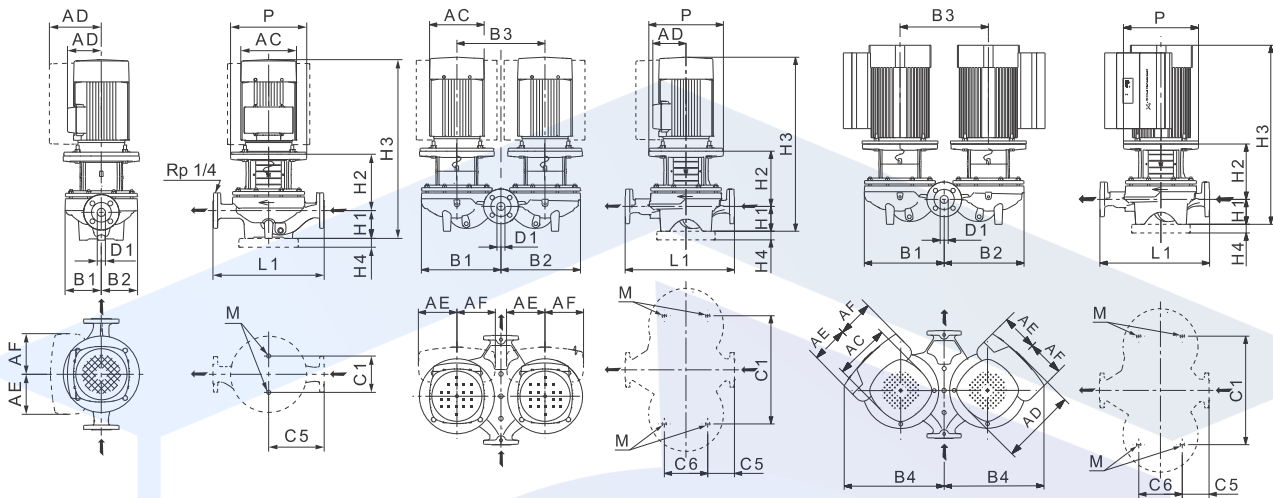

TM02 8632 2614 - TM02 8631 2614 - TM06 2653 4614

**Technical data**

TP 100	-120/2	-160/2	-200/2	-240/2	-250/2	-310/2	-360/2	-390/2	-480/2
TPD	•	•	•	•	•	•	•	•	•
TPE	•	•	•	•	•	•	•	•	•***
TPED	•	•	•	•	•	•	•	•	-
Series	200	300	300	300	300	300	300	300	300
IEC size	1~ TP	-	-	-	-	-	-	-	-
	3~ TP	90	112	132	132	160	160	160	180
P2	1~3~ TP ★ [kW]	-/2.2	-/4	-/5.5	-/7.5	-/11	-/15	-/18.5	-/22
	1~3~ TPE [kW]	-/2.2	-/4	-/5.5	-/7.5	-/11	-/15	-/18.5	-/22
PN	PN 6/10	PN 16	PN 16	PN 16	PN 16	PN 16	PN 16	PN 16	PN 16
T <sub>min</sub> , T <sub>max</sub>	[°C]	[-25;140]	[-25;120]	[-25;120]	[-25;120]	[-25;120]	[-25;120]	[-25;120]	[-25;120]
D1	[mm]	100	100	100	100	100	100	100	100
AC	1~3~ TP [mm]	-/178	-/220	-/220	-/260	-/314	-/314	-/314	-/407
	1~3~ TPE [mm]	-/122	-/191	-/191	-/255	-/255	-/314	-/314	-/407
AD	1~3~ TP [mm]	-/110	-/134	-/134	-/159	-/204	-/204	-/204	-/315
	1~3~ TPE [mm]	-/158	-/201	-/201	-/237	-/237	-/308	-/308	-/470
AE	1~3~ TPE [mm]	-/134	-/146	-/146	-/173	-/173	-/210	-/210	-/126
AF	1~3~ TPE [mm]	-/134	-/146	-/146	-/173	-/173	-/210	-/210	-/126
P	[mm]	-	250	300	300	350	350	350	400
B1 ★★	[mm]	125/245	156/347	156/347	156/347	190/414	190/414	190/414	201/443
B2 ★★	[mm]	100/265	124/332	124/332	124/332	151/395	151/395	151/395	173/429
B3	[mm]	280	470	470	470	470	500	500	500
B4 ★★	[mm]	-/340	-/481	-/481	-/526	-/541	-	-	-
C1 ★★	[mm]	160/280	144/480	144/480	144/480	230/550	230/550	230/550	230/550
C5 ★★	[mm]	225/83	250/104	250/104	250/104	275/110	275/110	275/110	275/110
C6	[mm]	221	175	175	175	230	230	230	230
L1	[mm]	450	500	500	500	550	550	550	550
H1	[mm]	107	140	140	140	140	140	140	140
H2	[mm]	185	206	245	245	270	270	270	307
H3	1~3~ TP [mm]	-/613	-/718	-/776	-/764	-/881	-/881	-/925	-/1058
	1~3~ TPE [mm]	-/566	-/680	-/750	-/774	-/816	-/881	-/925	-/1058
H4	[mm]	-	-	-	-	35	35	35	35
M		M16	M16	M16	M16	M16	M16	M16	M16

★ TP, TPD pumps are primarily fitted with IE3 motors. See *Motor data* on page 125.

★★ The dimension before the slash applies to the single-head pump, and the dimension after the slash applies to the twin-head pump.

★★★ The integrated CUE can be positioned in an angle deviating from this drawing with up to 30 degrees. For further information look in Grundfos Product Center.



**EDUPUMP**  
WWW.EDUPUMP.IR

## اولین و بزرگترین

سایت تخصصی سیستم‌های پمپاژ  
با امکان محاسبه آنلاین و انتخاب پمپ

## تولید بوستر پمپ آتش نشانی

در کلاس‌های S3 - S2 - S1  
مورد تایید سازمان آتش نشانی تهران



اولین و بزرگترین مرجع انتخاب آنلاین سیستم‌های پمپاژ

انتخاب آنلاین انواع بوستر پمپ

انتخاب آنلاین انواع پمپ

ارائه مطالب تخصصی

## اولین سایت مرجع

## انتخاب آنلاین پمپ

در حوزه‌های:

ایمنی و آتش نشانی  
آب و فاضلاب  
صنایع غذایی  
استخر  
صنعت  
معدن



## تولید بوستر پمپ

## آبرسانی دور متغیر

بدون محدودیت برند



## آموزش

تهویه و تخلیه دود  
سیستم‌های پمپاژ  
ایمنی معماری  
اطفاء حریق  
اعلام حریق

## مشاوره - طراحی - اجراء

تاسیسات مکانیکی (موتورخانه - استخر)  
تهویه و تخلیه دود  
سیستم‌های پمپاژ  
ایمنی معماری  
اعلام حریق  
اطفاء حریق

تهران، سعدی شمالی، خیابان مرادی نور، پلاک ۳۱

تلفن: ۰۲۱-۷۷۶۸۶۹۶۶ فکس: ۰۲۱-۷۷۶۷۸۶۵۹

EDUPUMP.IR

WWW.EDUPUMP.IR