

6. TP Series 100 and 200 pumps



Fig. 9 TP Series 100 and TP Series 200

Technical data

Flow rate:	Up to 90 m ³ /h
Head:	Up to 27 m
Liquid temperature, TP Series 100:	-25 to +120 °C
Liquid temperature, TP Series 200:	-25 to +140 °C
Maximum operating pressure:	Up to 16 bar
Direction of rotation:	Counterclockwise

Construction

Grundfos TP Series 100 and Series 200 pumps are single-stage, close-coupled pumps with in-line inlet and outlet ports of identical diameter.

The pumps are fitted with a fan-cooled asynchronous motor. Motor and pump shafts are connected via a rigid two-part coupling.

TP Series 100 pumps with union connection are available as single-head, TP, pumps.

TP Series 200 pumps are available as single-head, TP, and twin-head, TPD, pumps.

TP Series 200 pumps have PN 6 or PN 10 flanges.

The pumps are fitted with an unbalanced mechanical shaft seal.

The pumps are of the top-pull-out design, that is you can remove the power head (motor, pump head and impeller) for maintenance or service while the pump housing remains in the pipes.

The twin-head pumps are designed with two parallel power heads. A flap valve in the common outlet port is opened by the flow of the pumped liquid and prevents backflow of liquid into the idle pump head.

As radial and axial forces are absorbed by the fixed bearing in the motor drive-end, the pump requires no bearing.

The pumps are fitted with high-efficiency motors.

Pumps with a bronze or stainless-steel pump housing are suitable for circulation of domestic hot water.

Materials

TP Series 100

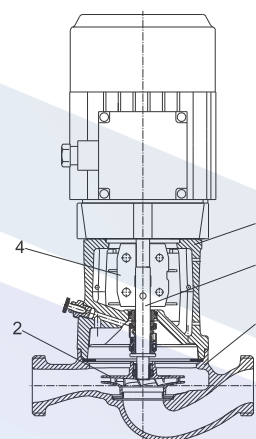

Fig. 10 Sectional drawing of TP Series 100 with union connection

Material specification, Series 100

Pos.	Component	Material	EN/DIN
1	Pump housing	Cast iron EN-GJL-150, EN-GJL-200, stainless steel	EN-JL 1020 EN-JL 1030 1.4308
2	Impeller	Composite PES/PP 30 % GF	
3	Shaft	Stainless steel	1.4057
4	Coupling	Cast iron EN-GJL-400	0.7040
5	Pump head	Cast iron EN-GJL-200, stainless steel	EN-JL 1030 1.4308
	Secondary seals	EPDM	
	Rotating seal face	Silicon carbide	
	Stationary seat	Carbon (resin-impregnated), silicon carbide	

EDUPUMP.IR

1. Pump data

Introduction

TP pumps are designed for applications such as:

- district heating systems
- heating systems
- air-conditioning systems
- district cooling systems
- water supply
- industrial processes
- industrial cooling.

The pumps are available with either mains-operated motors (TP and TPD) or electronically speed-controlled motors (TPE, TPED, TPE2, TPE2 D, TPE3, TPE3 D).

The pumps are all single-stage, in-line centrifugal pumps with mechanical shaft seal. The pumps are of the close-coupled type, that is the pump and the motor are separate units.

TP, mains-operated pumps

The TP range is divided into three groups based on their construction: TP Series 100, 200 and 300.

TP Series 100 with union or flange connection

Rp 1 (DN 25) to Rp 1 1/4 (DN 32) and motor sizes from 0.12 to 0.25 kW.

For further information, see page 27.

TP Series 200 with flange connection

DN 32 to DN 100 and motor sizes from 0.12 to 2.2 kW.

For further information, see page 27.

TP Series 300 with flange connection

We offer two versions:

- 16-bar version with DN 32 to DN 350 flanges and motor sizes from 0.25 to 315 kW
- 25-bar version with DN 100 to DN 400 flanges and motor sizes from 5 to 630 kW.

For further information, see page 29.

TPE, TPE2 and TPE3 speed-controlled pumps

We offer the following speed-controlled pumps which are based on the construction and choice of material of the TP pumps:

- TPE Series 1000 pumps without factory-fitted differential-pressure sensor.
- TPE Series 2000 pumps with factory-fitted differential-pressure sensor.
- TPE2 pumps without built-in differential-pressure sensor and temperature sensor.
- TPE3 pumps with built-in differential-pressure sensor and temperature sensor.

All pumps with 2-pole motors up to 11 kW and 4-pole motors up to 7.5 kW are fitted with Grundfos permanent-magnet MGE motors with motor efficiency class IE5 according to IEC 60034-30-2.

TPE Series 1000 pumps

The motors have a built-in frequency converter.

Via an external signal from a sensor or a controller, the pumps allow for any configuration and control method required, that is constant pressure, temperature or flow.

For further information, see page 32.

TPE Series 2000 pumps

The pumps have a factory-fitted differential-pressure sensor.

The pumps are factory-set to proportional-pressure control.

The motors have a built-in frequency converter for continuous adjustment of the pressure to the flow rate.

The range is recognised as a preset solution for quick and safe installation. Pumps fitted with 2-pole motors below 15 kW and 4-pole motors below 11 kW have a colour display for easy and intuitive pump setup and with full access to all functions.



Fig. 1 Example of main display on a TPE Series 2000 with advanced control panel

For further information, see page 35.

TM05 8893 2813

EDUPUMP.IR

Performance range, 2-pole, PN 6, 10, 16

See page 174 for performance curves.

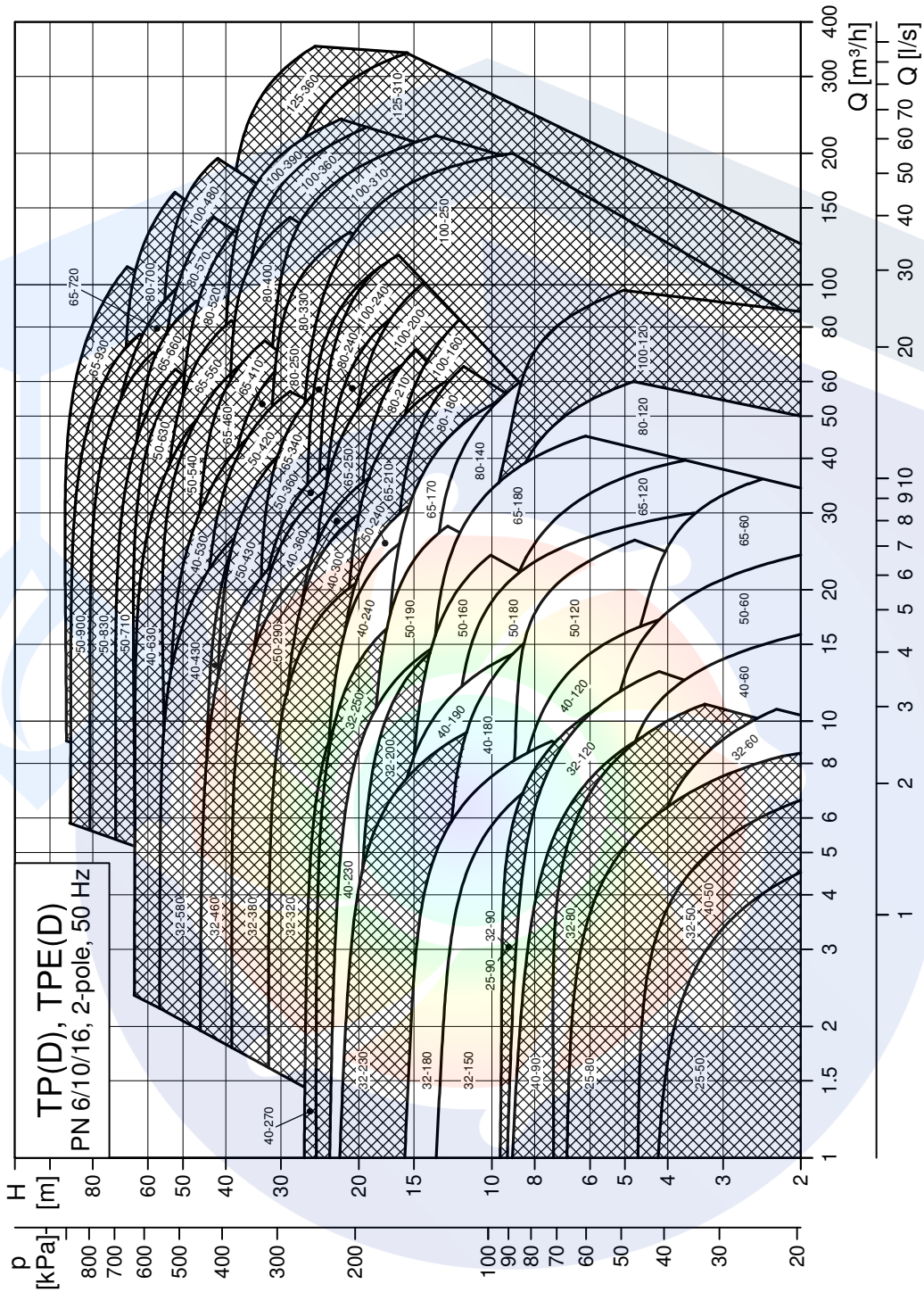

Note: All QH curves apply to single-head pumps. For further information about curve conditions, see page 160. The hatched area shows the performance range of TPE pumps.

EDUPUMP.IR

TM02 7550 2218

TP, TPE 32-XX/2

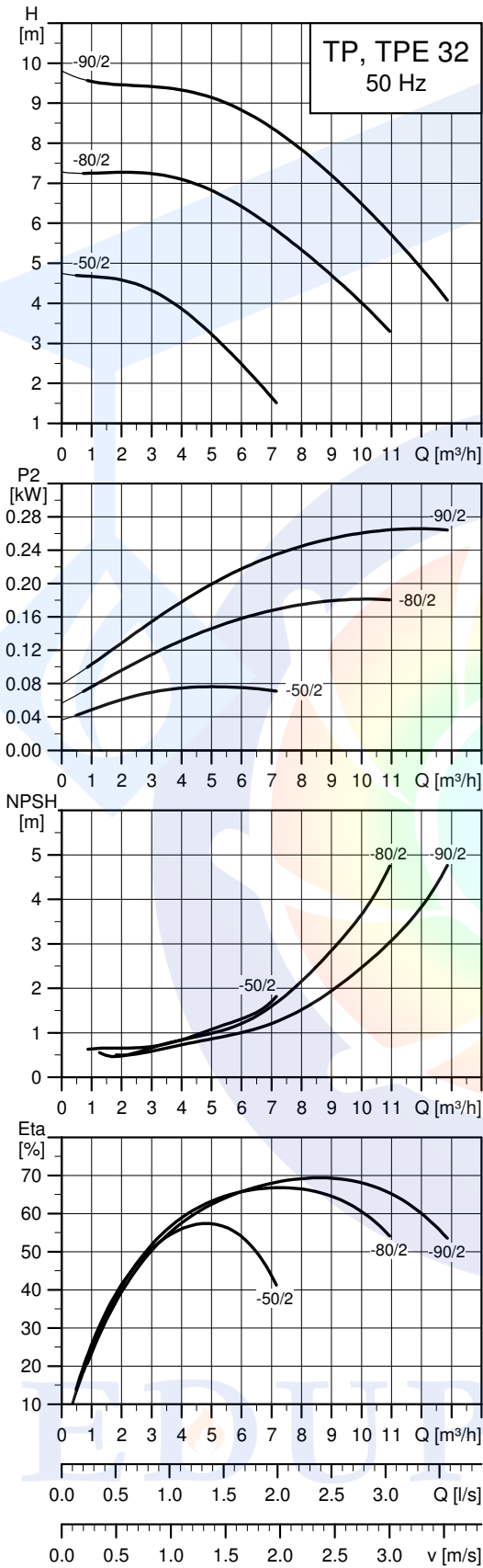

TM02 5015 4617

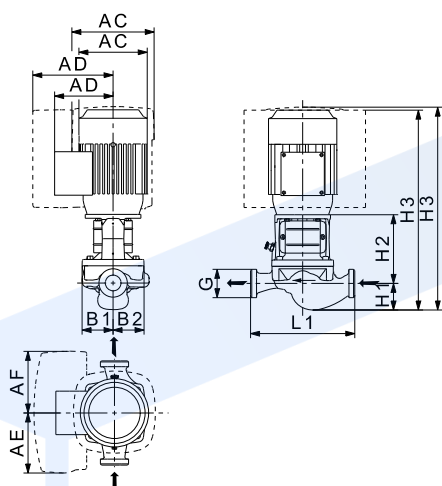

TM02 8348 2614

Technical data

TP 32		-50/2	-80/2	-90/2
TPD		-	-	-
TPE		•	•	•
TPED		-	-	-
Series		100	100	100
IEC size	1~ TP	63	63	71
	3~ TP	63	63	71
	1~ TPE	71	71	71
	3~ TPE	-	-	-
P2	1~3~ TP [kW]	0.12/0.12	0.25/0.25	0.37/0.37
	1~3~ TPE [kW]	0.12/-	0.25/-	0.37/-
PN		10	10	10
T _{min} :T _{max}	[°C]	[-25;110]	[-25;110]	[-25;110]
G		G 2	G 2	G 2
AC	1~3~ TP [mm]	141/124	141/124	141/141
	1~3~ TPE [mm]	122/-	122/-	122/-
AD	1~3~ TP [mm]	133/101	133/101	133/109
	1~3~ TPE [mm]	158/-	158/-	158/-
AE	1~3~ TPE [mm]	106/-	106/-	106/-
AF	1~3~ TPE [mm]	106/-	106/-	106/-
B1	[mm]	54	54	60
B2	[mm]	62	62	68
L1	[mm]	180	180	180
H1	[mm]	48	48	47
H2	[mm]	120	120	120
H3	1~3~ TP [mm]	359/347	359/347	357/357
	1~3~ TPE [mm]	382/-	382/-	380/-

EDUPUMP.IR



EDUPUMP
WWW.EDUPUMP.IR

اولین و بزرگترین

سایت تخصصی سیستم‌های پمپاژ
با امکان محاسبه آنلاین و انتخاب پمپ

تولید بوستر پمپ آتش نشانی

در کلاس‌های S3 - S2 - S1
مورد تایید سازمان آتش نشانی تهران



اولین و بزرگترین مرجع انتخاب آنلاین سیستم‌های پمپاژ

انتخاب آنلاین انواع بوستر پمپ

انتخاب آنلاین انواع پمپ

ارائه مطالب تخصصی

اولین سایت مرجع

انتخاب آنلاین پمپ

در حوزه‌های:

ایمنی و آتش نشانی
آب و فاضلاب
صنایع غذایی
استخر
صنعت
معدن

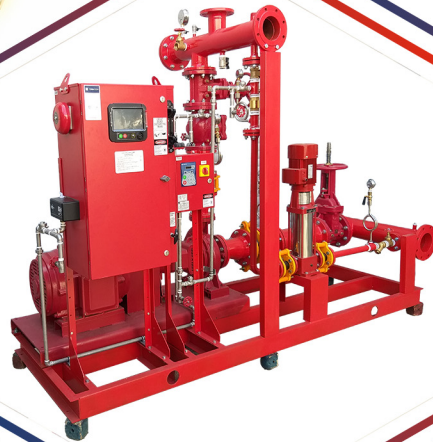

تولید بوستر پمپ

آبرسانی دور متغیر

بدون محدودیت برند



آموزش

تهویه و تخلیه دود
سیستم‌های پمپاژ
ایمنی معماری
اطفاء حریق
اعلام حریق

مشاوره - طراحی - اجراء

تاسیسات مکانیکی (موتورخانه - استخر)
تهویه و تخلیه دود
سیستم‌های پمپاژ
ایمنی معماری
اعلام حریق
اطفاء حریق

تهران، سعدی شمالی، خیابان مرادی نور، پلاک ۳۱

تلفن: ۰۲۱-۷۷۶۸۶۹۶۶ فکس: ۰۲۱-۷۷۶۷۸۶۵۹

EDUPUMP.IR

WWW.EDUPUMP.IR