

### Series description Wilo-TOP-S

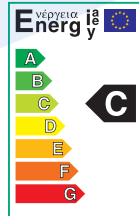

**> Note**

EEL classification for each pump type, see Chapter: "Planning guide"

**Design**

Glandless circulation pump with screwed connection or flange connection. Preselectable speed stages for power adjustment.

**Application**

Hot-water heating systems of all kinds, industrial circulation systems, air-conditioning systems and closed cooling circuits

**Type key**

Example: **TOP-S 40/10**  
**TOP-S** Standard pump (screw-end or flange-end pump)  
**40/** Nominal connection diameter  
**10** Nominal delivery head range [m] at  $Q = 0 \text{ m}^3/\text{h}$

**Options**

- Special version for operating pressure PN 16 (at additional charge)
- Version for special voltages on request.

**Special features/product benefits**

- Can be used in heating systems and in cooling/air-conditioning systems from  $-20 \text{ }^\circ\text{C}$  to  $+130 \text{ }^\circ\text{C}$
- Manual power adjustment with 2 speed stages (for pumps 1~230 V with  $P_2 \geq 350 \text{ W}$ ) or with 3 speed stages
- Pump housing with cathaphoretic (KTL) coating for the prevention of corrosion by condensation formation
- With thermal insulation as standard
- Simple installation due to combination flange PN 6/PN 10 (for DN 40 to DN 65)
- Cable feed in to terminal box possible on both sides (from  $P_2 \geq 180 \text{ W}$ ) with integrated strain relief device
- Protection class IP 44

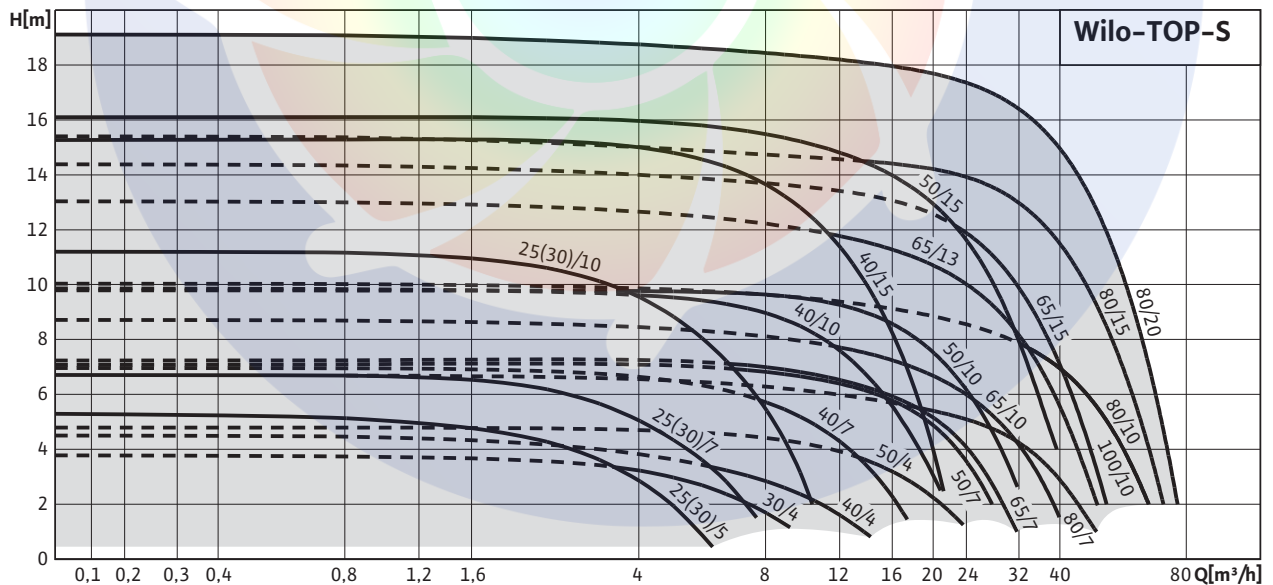

Heating, air-conditioning, cooling

### Pump curves Wilo-TOP-S

#### Wilo-TOP-S 30/4

Alternating current

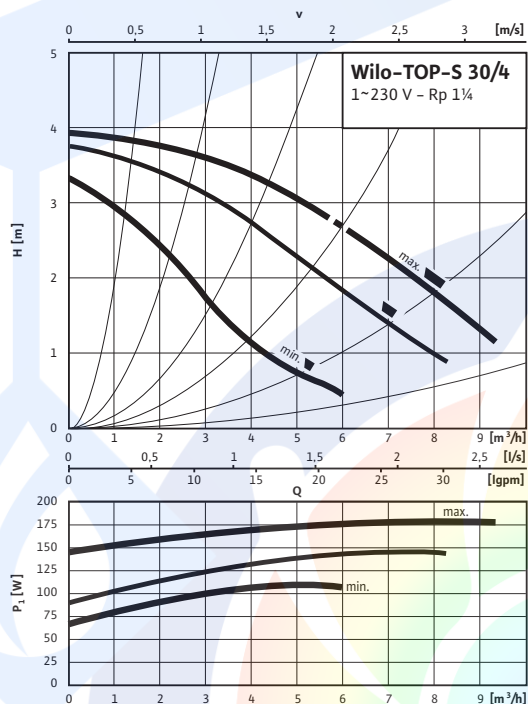

Three-phase current

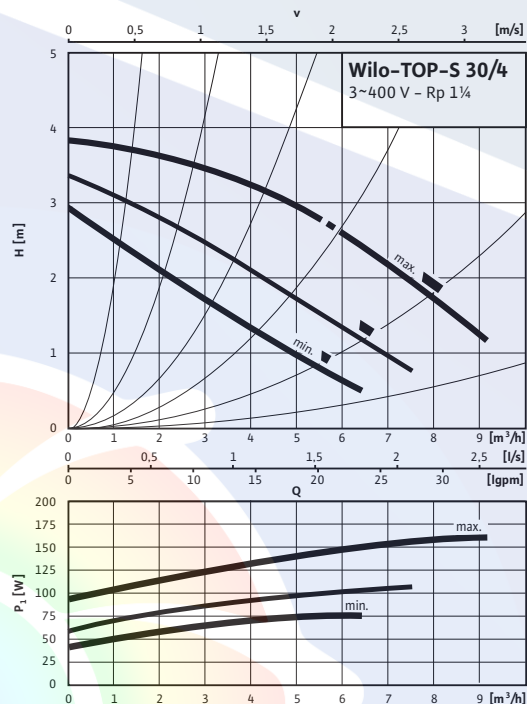

#### Wilo-TOP-S 40/4

Alternating current

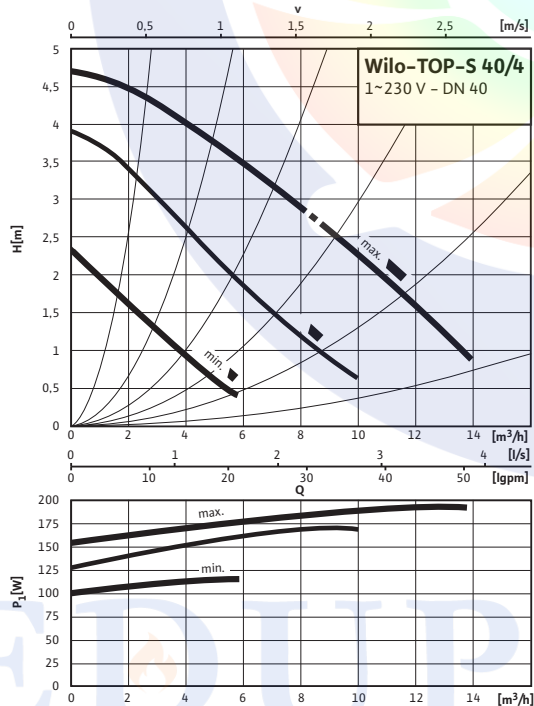

Three-phase current

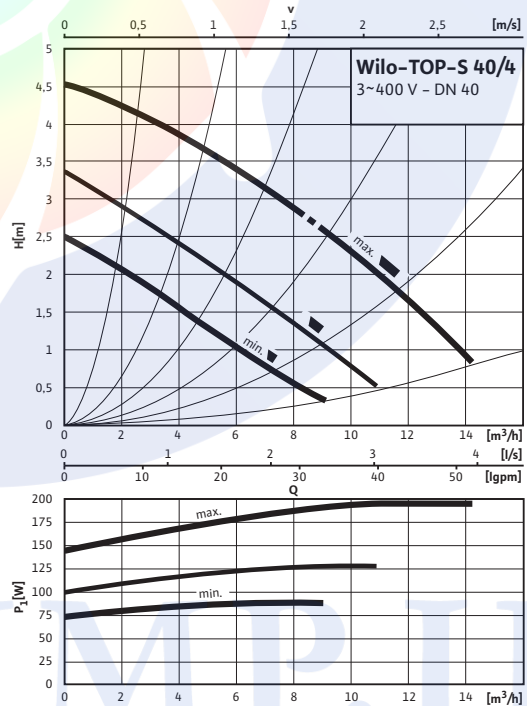

Heating, air-conditioning, cooling

# Heating, air-conditioning, cooling

Standard pumps (single pumps)



## Terminal diagram, motor data Wilo-TOP-S

Motor data											
Wilo-TOP-S ...	Nominal motor power	Speed	Power consumption 1~230 V	Power consumption 3~400 V	Current at 1~230V	Current at 3~400V	Current at 3~230V	Capacitor	Motor protection	Threaded cable connection	Wiring diagram
	P <sub>2</sub>	n	P <sub>1</sub>		I			C	–	PG	–
	[W]	[rpm]	[W]		[A]			[µF/VDB]	–	[PG]	–
30/10 (1-phase-motor)	180	max. 2700 2550 min. 2400	225 - 390 190 - 385 165 - 335	–	1,9 1,87 1,72	–	–	8,0/400	C	2x13,5	C
30/10 (3-phase-motor)	180	max. 2650 2250 min. 1950	–	190 - 380 140 - 270 115 - 195	–	0,78 0,48 0,35	1,35 0,84 0,61	–	D	2x13,5	D
40/4 (1-phase-motor)	90	max. 2500 2100 min. 1600	155 - 195 130 - 175 100 - 120	–	0,95 0,87 0,62	–	–	5,0/400	A	1x13,5	A
40/4 (3-phase-motor)	90	max. 2550 2050 min. 1700	–	145 - 195 100 - 130 70 - 90	–	0,45 0,25 0,17	0,78 0,43 0,30	–	B	1x13,5	B
40/7 (1-phase-motor)	180	max. 2650 2450 min. 2200	250 - 390 220 - 380 200 - 330	–	1,93 1,88 1,7	–	–	8,0/400	C	2x13,5	C
40/7 (3-phase-motor)	180	max. 2600 2100 min. 1800	–	220 - 370 165 - 260 130 - 185	–	0,76 0,47 0,33	1,31 0,81 0,57	–	D	2x13,5	D
40/10 (1-phase-motor)	350	max. 2800 min. 2600	430 - 680 310 - 610	–	3,47 3,18	–	–	16,0/ 400	F	2x13,5	F
40/10 (3-phase-motor)	350	max. 2800 2500 min. 2200	–	300 - 585 230 - 465 200 - 365	–	1,17 0,82 0,65	2,02 1,43 1,12	–	D	2x13,5	D
40/15 (1-phase-motor)	570	max. 2800 min. 2500	615 - 945 415 - 800	–	4,57 4,2	–	–	25,0/ 400	F	2x13,5	F
40/15 (3-phase-motor)	570	max. 2800 2500 min. 2150	–	500 - 905 375 - 720 325 - 585	–	1,84 1,30 1,05	3,19 2,25 1,82	–	D	2x13,5	D
50/4 (1-phase-motor)	180	max. 2650 2450 min. 1950	280 - 330 255 - 320 235 - 290	–	1,62 1,61 1,51	–	–	8,0/400	C	2x13,5	C
50/4 (3-phase-motor)	180	max. 2600 2100 min. 1700	–	245 - 330 190 - 240 145 - 180	–	0,71 0,44 0,32	1,23 0,76 0,56	–	D	2x13,5	D
50/7 (1-phase-motor)	350	max. 2800 min. 2600	460 - 690 360 - 630	–	3,49 3,35	–	–	16,0/ 400	F	2x13,5	F
50/7 (3-phase-motor)	350	max. 2800 2450 min. 2150	–	360 - 610 285 - 470 245 - 375	–	1,19 0,83 0,66	2,06 1,43 1,14	–	D	2x13,5	D
50/10 (1-phase-motor)	450	max. 2800 min. 2450	515 - 820 360 - 730	–	3,94 3,72	–	–	25,0/ 400	F	2x13,5	F
50/10 (3-phase-motor)	450	max. 2700 2300 min. 2000	–	450 - 880 330 - 680 280 - 500	–	1,73 1,20 0,89	3,00 2,09 1,54	–	D	2x13,5	D

Heating, air-conditioning, cooling

### Dimensions, weights Wilo-TOP-S

**Dimension drawing A**

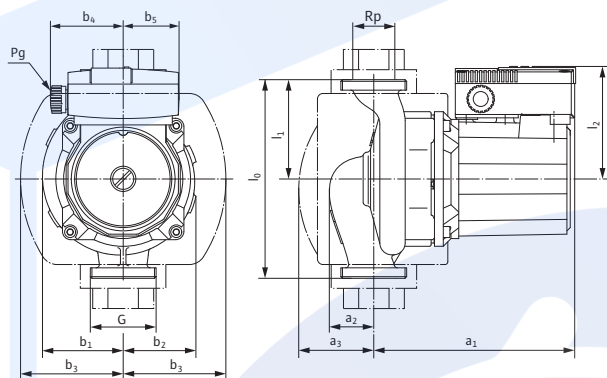

Permitted installation positions, see Planning guide

**Dimension drawing B**

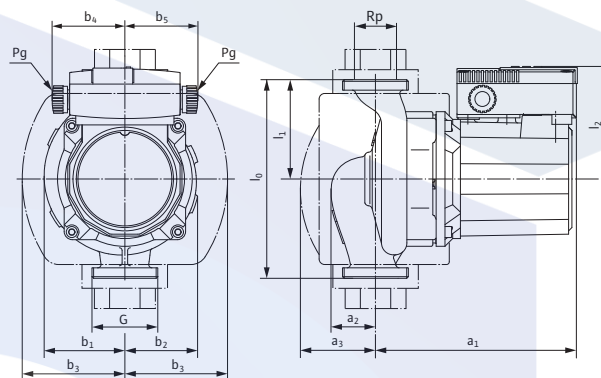

Permitted installation positions, see Planning guide

**Dimension drawing C**

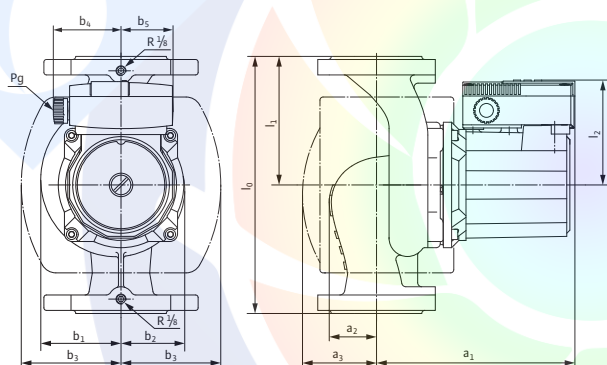

Permitted installation positions, see Planning guide

**Dimension drawing D**

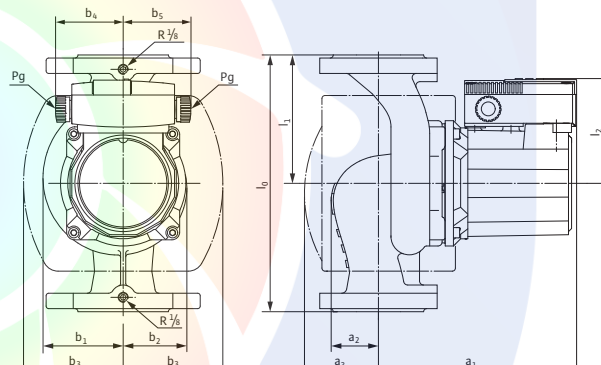

Permitted installation positions, see Planning guide

**Dimension drawing E**

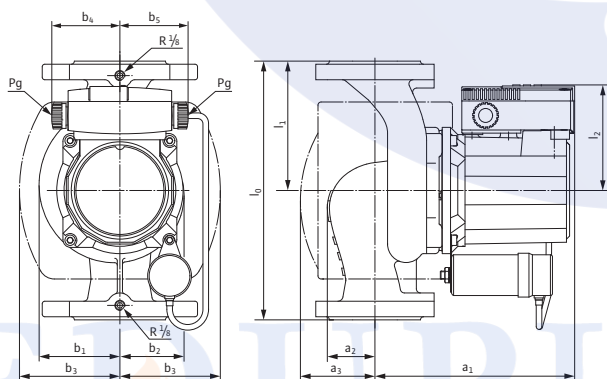

Permitted installation positions, see Planning guide

Heating, air-conditioning, cooling

# Heating, air-conditioning, cooling

Standard pumps (single pumps)

## Dimensions, weights Wilo-TOP-S

Dimension drawing Flange F

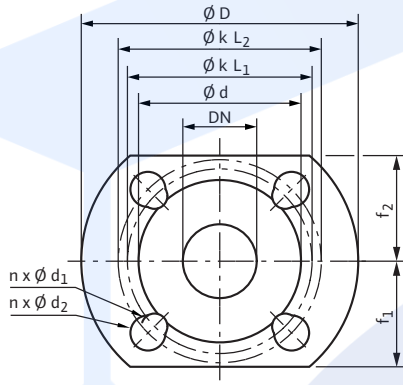

Dimension drawing Flange G

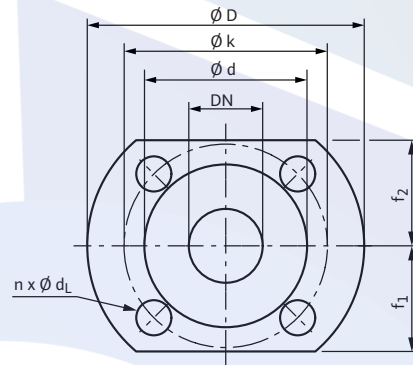

### Dimensions, weights

Wilo-TOP-S ...	Rated pressure	Pipe connection	Nominal flange diameter	Thread	Dimensions									Weight approx.	Dimension drawing
	PN	Rp	DN	G	l <sub>0</sub>	l <sub>2</sub>	a <sub>1</sub>	a <sub>2</sub>	b <sub>1</sub>	b <sub>2</sub>	b <sub>3</sub>	b <sub>4</sub>	b <sub>5</sub>	M	-
	[bar]	-	-	-	[mm]									[kg]	-
25/5	10	1	-	1½	180	92	150	40	50	52	88	60	44	5.0	A
25/7	10	1	-	1½	180	92	165	34	66	56	80	60	44	5.0	A
25/10	10	1	-	1½	180	102	172	45	69	68	92	66	66	6.3	B
25/13	10	1	-	1½	180	92	156	30	68	64	89	60	44	5.2	A
30/4	10	1¼	-	2	180	92	156	50	53	65	88	60	44	5.0	A
30/5	10	1¼	-	2	180	92	150	40	50	52	88	60	44	5.0	A
30/7	10	1¼	-	2	180	92	172	34	66	57	88	60	44	5.0	A
30/10	10	1¼	-	2	180	102	172	45	69	69	92	66	66	6.3	B
40/4	6/10	-	40	-	220	90	178	54	84	60	102	53	44	9.5	C
40/7	6/10	-	40	-	250	102	193	46	78	68	102	66	66	11.0	D
40/10	6/10	-	40	-	250	109	216	59	90	80	117	66	66	14.7	D
40/15	6/10	-	40	-	250	119	258	55	99	86	137	66	66	20.8	D
50/4	6/10	-	50	-	240	102	200	53	94	68	117	66	66	13.1	D
50/7	6/10	-	50	-	280	109	224	65	91	77	125	66	66	16.6	D
50/10	6/10	-	50	-	280	109	222	71	101	87	125	66	66	17.8	D
50/15	6/10	-	50	-	340	119	242	81	105	90	139	66	66	24.9	D
65/7	6/10	-	65	-	280	109	226	67	95	79	125	66	66	18.5	D
65/10	6/10	-	65	-	340	109	241	67	110	89	132	66	66	21.0	D
65/13	6/10	-	65	-	340	119	254	81	118	98	142	66	66	27.2	D
65/15	6/10	-	65	-	340	119	254	81	118	98	142	66	66	30.4	D
80/7	6	-	80	-	360	109	227	80	116	89	140	66	66	23.4	E
80/7	10	-	80	-	360	109	227	80	116	89	140	66	66	23.2	D
80/10	6	-	80	-	360	119	256	95	135	107	162	66	66	30.1	D
80/10	10	-	80	-	360	119	256	95	135	107	162	66	66	30.1	D
80/15	6	-	80	-	360	143	316	89	129	108	152	66	66	42.1	D
80/15	10	-	80	-	360	143	316	89	129	108	152	66	66	42.1	D

### Dimensions, weights Wilo-TOP-S

#### Dimensions, weights

Wilo-TOP-S ...	Rated pressure	Pipe connection	Nominal flange diameter	Thread	Dimensions										Weight approx.	Dimension drawing
	PN	Rp	DN	G	l <sub>0</sub>	l <sub>2</sub>	a <sub>1</sub>	a <sub>2</sub>	b <sub>1</sub>	b <sub>2</sub>	b <sub>3</sub>	b <sub>4</sub>	b <sub>5</sub>	M	–	
	[bar]	–			[mm]										[kg]	–
80/20	6	–	80	–	360	143	316	89	129	108	152	66	66	45.5	D	
80/20	10	–	80	–	360	143	316	89	129	108	152	66	66	45.5	D	
100/10	6	–	100	–	360	119	256	96	135	108	162	66	66	33.2	D	
100/10	10	–	100	–	360	119	256	96	135	108	162	66	66	33.2	D	

#### Flange dimensions

Wilo-TOP-S ...	Flange	Nominal flange diameter	Pump flange dimensions									Dimension drawing, flange
			DN	∅ D	f <sub>1</sub>	f <sub>2</sub>	∅ d	∅ k <sub>L1</sub> /k <sub>L2</sub>	∅ k	n x ∅ d <sub>L1</sub> / ∅ d <sub>L2</sub>	n x ∅ d <sub>L</sub>	
			[mm]									
40/4	Combination flange PN6/10 (PN 16 flange according to EN 1092-2)	40	150	65	65	84	100/110	–	4 x 14 / 19	–	F	
40/7	Combination flange PN6/10 (PN 16 flange according to EN 1092-2)	40	150	65	65	84	100/110	–	4 x 14 / 19	–	F	
40/10	Combination flange PN6/10 (PN 16 flange according to EN 1092-2)	40	150	65	65	84	100/110	–	4 x 14 / 19	–	F	
40/15	Combination flange PN6/10 (PN 16 flange according to EN 1092-2)	40	150	65	65	84	100/110	–	4 x 14 / 19	–	F	
50/4	Combination flange PN6/10 (PN 16 flange according to EN 1092-2)	50	165	70	70	99	110/125	–	4 x 14 / 19	–	F	
50/7	Combination flange PN6/10 (PN 16 flange according to EN 1092-2)	50	165	70	70	99	110/125	–	4 x 14 / 19	–	F	
50/10	Combination flange PN6/10 (PN 16 flange according to EN 1092-2)	50	165	70	75	99	110/125	–	4 x 14 / 19	–	F	
50/15	Combination flange PN6/10 (PN 16 flange according to EN 1092-2)	50	165	75	83	99	110/125	–	4 x 14 / 19	–	F	
65/7	Combination flange PN6/10 (PN 16 flange according to EN 1092-2)	65	185	80	80	118	130/145	–	4 x 14 / 19	–	F	
65/10	Combination flange PN6/10 (PN 16 flange according to EN 1092-2)	65	185	80	80	118	130/145	–	4 x 14 / 19	–	F	
65/13	Combination flange PN6/10 (PN 16 flange according to EN 1092-2)	65	185	80	80	118	130/145	–	4 x 14 / 19	–	F	
65/15	Combination flange PN6/10 (PN 16 flange according to EN 1092-2)	65	185	80	80	118	130/145	–	4 x 14 / 19	–	F	



**EDUPUMP**  
WWW.EDUPUMP.IR

## اولین و بزرگترین

سایت تخصصی سیستم‌های پمپاژ  
با امکان محاسبه آنلاین و انتخاب پمپ

## تولید بوستر پمپ آتش نشانی

در کلاس‌های S3 - S2 - S1  
مورد تایید سازمان آتش نشانی تهران



اولین و بزرگترین مرجع انتخاب آنلاین سیستم‌های پمپاژ

انتخاب آنلاین انواع بوستر پمپ

انتخاب آنلاین انواع پمپ

ارائه مطالب تخصصی

## اولین سایت مرجع

## انتخاب آنلاین پمپ

در حوزه‌های:

ایمنی و آتش نشانی  
آب و فاضلاب  
صنایع غذایی  
استخر  
صنعت  
معدن



## تولید بوستر پمپ

## آبرسانی دور متغیر

بدون محدودیت برند



## آموزش

تهویه و تخلیه دود  
سیستم‌های پمپاژ  
ایمنی معماری  
اطفاء حریق  
اعلام حریق

## مشاوره - طراحی - اجراء

تاسیسات مکانیکی (موتورخانه - استخر)  
تهویه و تخلیه دود  
سیستم‌های پمپاژ  
ایمنی معماری  
اعلام حریق  
اطفاء حریق

تهران، سعدی شمالی، خیابان مرادی نور، پلاک ۳۱

تلفن: ۰۲۱-۷۷۶۸۶۹۶۶ فکس: ۰۲۱-۷۷۶۷۸۶۵۹

EDUPUMP.IR

WWW.EDUPUMP.IR