



## Application

- Suitable for transferring liquids of low viscosity, non-inflammable and non-explosive, not containing solid particles or fibers
- Water supply & drainage for high-rise buildings, filtration and transfer at waterworks, pressure boosting in main pipe
- Washing and cleaning systems, boiler feeding, cooling water circulation, water treatment systems, auxiliary system, support equipment
- Ultra-filtration systems, reverse-osmosis systems, distillation systems, separators, swimming pools
- Agricultural irrigation: sprinkler irrigation, drip-feed irrigation
- Food & beverage industry
- Fire-fighting system

## Operating Conditions

- Low viscosity, non-inflammable and non-explosive liquids not containing solid particles or fibers. The liquids must not chemically attack the pump materials. When pumping liquids with a density or viscosity is higher than that of water, a motor with a higher output power rating shall be used.
- Liquid temperature: -20°C~+120°C
- Flow ranges: 0.7-240 m³/h
- Liquid pH value: 4 -10
- Max. ambient temperature: +40°C
- Max. operation pressure: 33 bar
- Altitude: up to 1000 m

## Motor

- IE 2 motor (IE 3 motor optional)
- Totally enclosed & fan-cooled
- Protection class: IP55
- Standard voltage: 50Hz 1 × 220V/3 × 380V

## Identification Codes

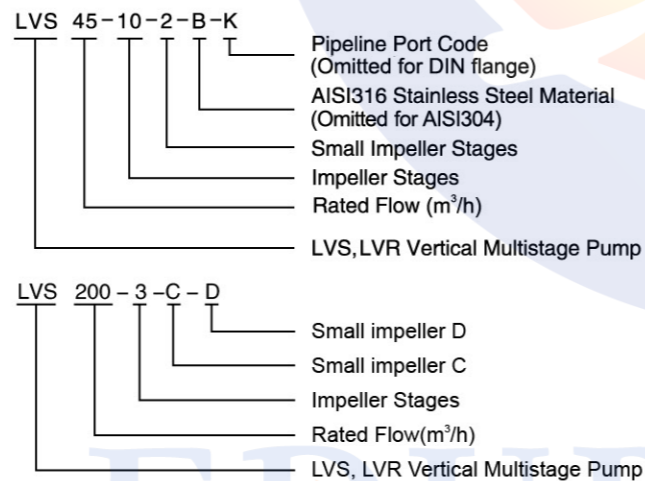

LVS: Stainless steel wetted parts  
LVR: Cast iron base & pump cover

### Identifications codes of flange structure

A: Oval flange : K: Clamp connector :  
G: Threaded connector

## Minimum Inlet Pressure-Npsh

Calculation of the inlet pressure "H" is recommended in these situations:

- The liquid temperature is high.
- The flow is significantly higher than the rated flow.
- Water is drawn from depths.
- Water is drawn through long pipes.
- Inlet conditions are poor.

To avoid cavitation, make sure that there is a minimum pressure on the suction side of the pump. The maximum suction lift "H" in meters head can be calculated as follows:

$$H = P_b \times 10.2 - NPSH - H_r - H_v - H_s$$

$P_b$  = Barometric pressure in bar. (Barometric pressure can be set to 1 bar). In closed systems,  $P_b$  indicates the system pressure in bar.

$NPSH$  = Net Positive Suction Head in meters head. (To be read from the NPSH curve at the highest flow the pump will be delivering.)

$H_r$  = Friction loss in suction pipe in meters head. (At the highest flow the pump will be delivering.)

$H_v$  = Vapor pressure in meters head. (To be read from the vapor pressure scale. "Hv" depends on the liquid temperature "tm")

$H_s$  = Safety margin=minimum 0.5 meters head.

If the "H" calculated is positive, the pump can operate at a suction lift of maximum "H" meters head.

If the "H" calculated is negative, an inlet pressure of minimum "H" meters head is required.

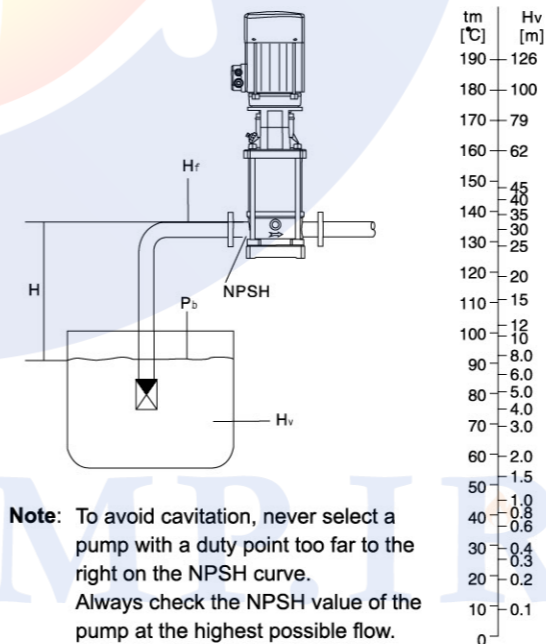

**Note:** To avoid cavitation, never select a pump with a duty point too far to the right on the NPSH curve. Always check the NPSH value of the pump at the highest possible flow.

## Maximum Inlet Pressure

The following table shows the maximum permissible inlet pressure. However, the current inlet pressure + the pressure against a closed valve must always be lower than the Max. permissible operating pressure.

If the maximum permissible operating pressure is exceeded, the bearing in the motor may be damaged and the life of the shaft seal reduced.

Model	Max. Inlet Pressure [bar]
LVR(S) 1-2 - 1-36	10
LVR(S) 2-2	6
LVR(S) 2-3 - 2-12	10
LVR(S) 2-13 - 2-26	15
LVR(S) 3-2 - 3-29	10
LVR(S) 3-31 - 3-36	15
LVR(S) 4-2	6
LVR(S) 4-3 - 4-11	10
LVR(S) 4-12 - 4-22	15
LVR(S) 5-2 - 5-16	10
LVR(S) 5-18 - 5-29	15
LVR(S) 10-1 - 10-6	8
LVR(S) 10-7 - 10-22	10
LVR(S) 15-1 - 15-3	8
LVR(S) 15-4 - 15-17	10
LVR(S) 20-1 - 20-3	8
LVR(S) 20-4 - 20-17	10
LVR(S) 32-1-1 - 32-4	4
LVR(S) 32-5-2 - 32-10	10
LVR(S) 32-11 - 32-14	15
LVR(S) 45-1-1 - 45-2	4
LVR(S) 45-3-2 - 45-5	10
LVR(S) 45-6-2 - 45-13-2	15
LVR(S) 64-1-1 - 64-2-2	4
LVR(S) 64-2-1 - 64-4-2	10
LVR(S) 64-4-1 - 64-8-1	15
LVR(S) 90-1-1 - 90-1	4
LVR(S) 90-2-2 - 90-3-2	10
LVR(S) 90-3 - 90-6	15
LVR(S) 120-1 - 120-2-1	10
LVR(S) 120-2 - 120-5-1	15
LVR(S) 120-5 - 120-7	20
LVR(S) 150-1-1 - 150-2-2	10
LVR(S) 150-2-1 - 150-4-1	15
LVR(S) 150-4 - 150-6	20
LVR(S) 200-1-D	10
LVR(S) 200-1-C - 200-2-2C	15
LVR(S) 200-2-C - 200-4	20

Model	LVR Max. Inlet Pressure [bar]		LVS Max. Inlet Pressure [bar]
	Oval Flange	DIN Flange	
LVR(S) 1	16	25	25
LVR(S) 2	16	25	25
LVR(S) 3	16	25	25
LVR(S) 4	16	25	25
LVR(S) 5	16	25	25
LVR(S) 10		25	25
LVR(S) 15		25	25
LVR(S) 20		25	25
LVR(S) 32-1-1 - 32-7	16		16
LVR(S) 32-8-2 - 32-14	30		30
LVR(S) 45-1-1 - 45-5	16		16
LVR(S) 45-6-2 - 45-11	30		30
LVR(S) 45-12-2 - 45-13-2	33		33
LVR(S) 64-1-1 - 64-5	16		16
LVR(S) 64-6-2 - 64-8-1	30		30
LVR(S) 90-1-1 - 90-4	16		16
LVR(S) 90-5-2 - 90-6	30		30
LVR(S) 120-1 - 120-7	20		20
LVR(S) 150-1-1 - 150-6	20		20
LVR(S) 200-1-D - 200-4	20		20

## Ambient Temperature

Max. ambient temperature: +40°C. Ambient temperature above 40°C or installation at altitude of more than 1000 meters above sea level require the use of an oversize motor. Because of low air density and poor cooling effects, the motor output power P2 will be decreased. See the picture.

In such cases, it may be necessary to use a motor with a higher output power rating.

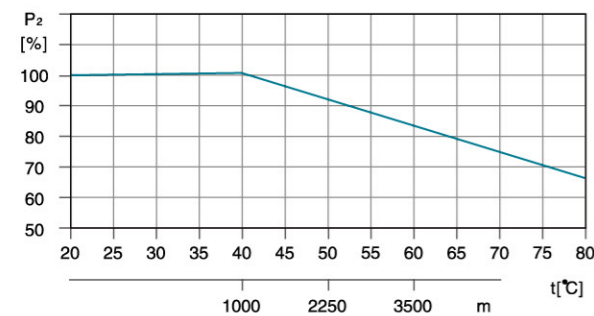

For example, when the pump is installed at altitude of more than 3500 meters above sea level, P2 will be decreased to 88%. When the ambient temperature is 70°C, P2 will be decreased to 78%.

**How to Read The Curve Charts**

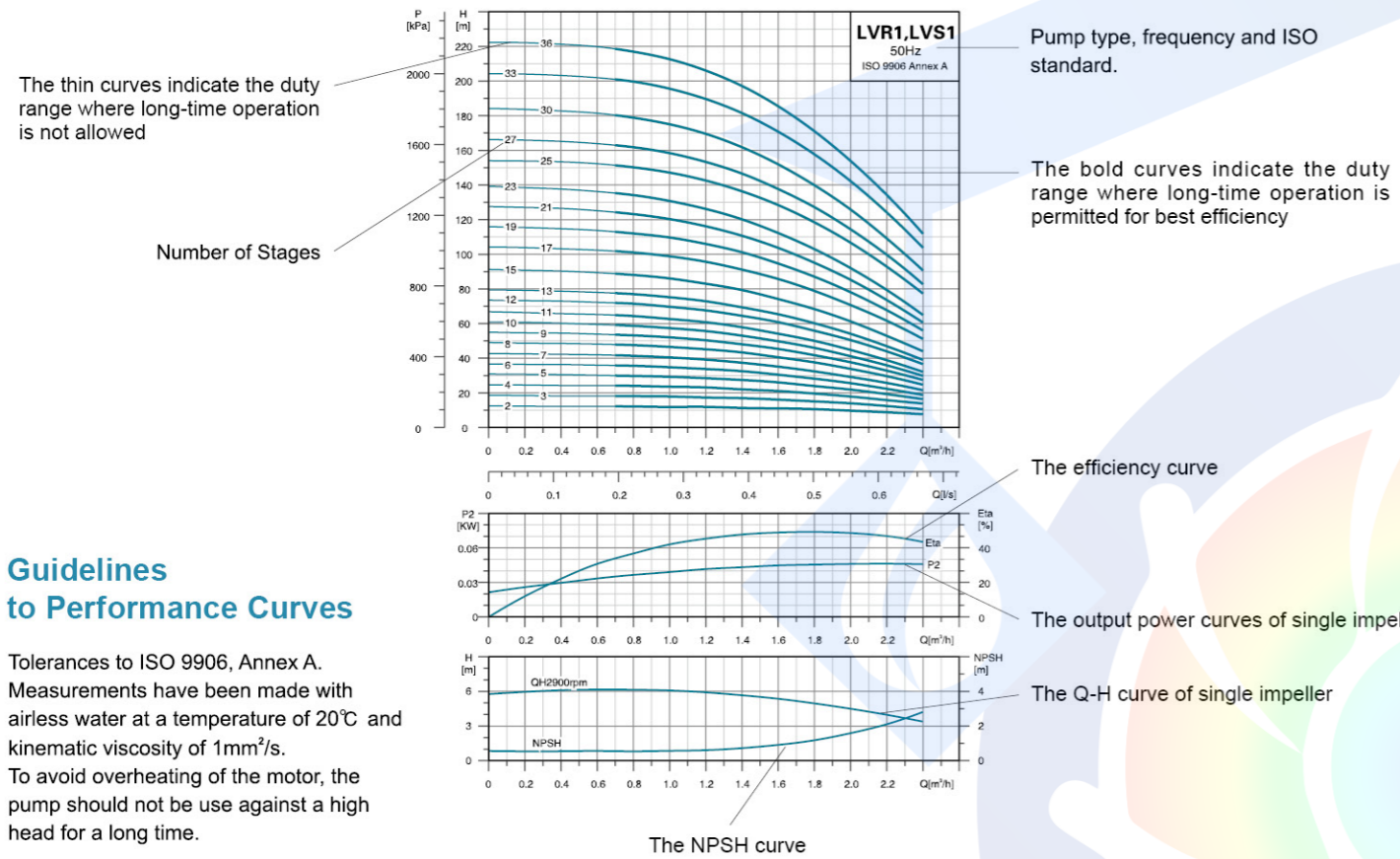

**Guidelines to Performance Curves**

Tolerances to ISO 9906, Annex A. Measurements have been made with airless water at a temperature of 20°C and kinematic viscosity of 1mm<sup>2</sup>/s. To avoid overheating of the motor, the pump should not be use against a high head for a long time.

**Minimum Flow Rate**

Due to the risk of overheating, the pump should not be used at a flow below the minimum flow rate. The curve below shows the minimum flow rate as a percentage of the nominal flow rate in relation to the liquid temperature.

Air cooling apparatus

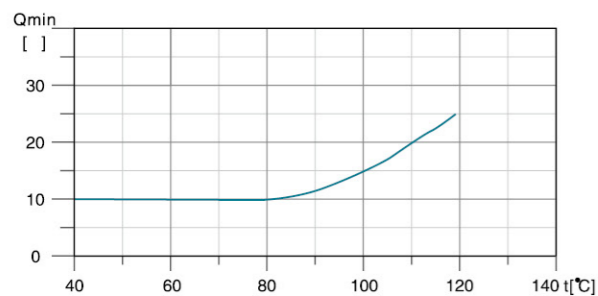

**Note:** The outlet valve must be opened when the pump is in operation.

**Terminal Box Positions**  
(Note: set to position 1 before delivery)

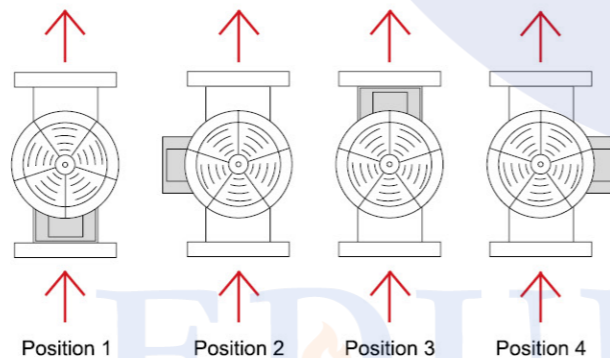

**Product Range**

MODEL	LVR(S)1	LVR(S)2	LVR(S)3	LVR(S)4	LVR(S)5	LVR(S)10	LVR(S)15	LVR(S)20	LVR(S)32	LVR(S)45	LVR(S)64	LVR(S)90	LVR(S)120	LVR(S)150	LVR(S)200
<b>DESCRIPTION</b>															
Rated flow [m <sup>3</sup> /h]	1	2	3	4	5	10	15	20	32	45	64	90	120	150	200
Flow range [m <sup>3</sup> /h]	0.7-2.4	1.0-3.5	1.2-4.5	1.5-8	2.5-8.5	5-13	8-23	10.5-29	15-40	22-58	30-85	45-120	60-150	80-180	100-240
Max. pressure [bar]	22	23	24	21	24	22	23	25	28	33	22	20	16	16	16
Motor power [kW]	0.37-2.2	0.37-3	0.37-3	0.37-4	0.37-4	1.1-7.5	1.1-15	1.1-18.5	1.5-30	3-45	4-45	5.5-45	11-75	11-75	18.5-110
Temperature Range [°C]	-20°C~+120°C ( Note: Both the Max. permissible pressure and liquid temperature range refer to the pump capacity.)														
Max. pump efficiency [%]	45	46	55	59	60	65	70	72	78	79	80	81	74	73	79
Pipe connection-LVR															
Oval flange	G1	G1	G1	G1 1/4	G1 1/4	-	-	-	-	-	-	-	-	-	-
DIN flange	DN25	DN25	DN25	DN32	DN32	DN40	DN50	DN50	DN65	DN80	DN100	DN100	DN125	DN125	DN150
Pipe connection-LVS															
Oval flange	-	-	-	-	-	-	-	-	-	-	-	-	-	-	-
DIN flange	DN32	DN32	DN32	DN32	DN32	DN40	DN50	DN50	DN65	DN80	DN100	DN100	DN125	DN125	DN150
Clamp connector	φ 42	φ 42	φ 42	φ 42	φ 42	-	-	-	-	-	-	-	-	-	-
Threaded connector	R <sub>2</sub> 1 1/4	R <sub>2</sub> 1 1/4	R <sub>2</sub> 1 1/4	R <sub>2</sub> 1 1/4	R <sub>2</sub> 1 1/4	-	-	-	-	-	-	-	-	-	-

**Scope of Performance-LVR,LVS**

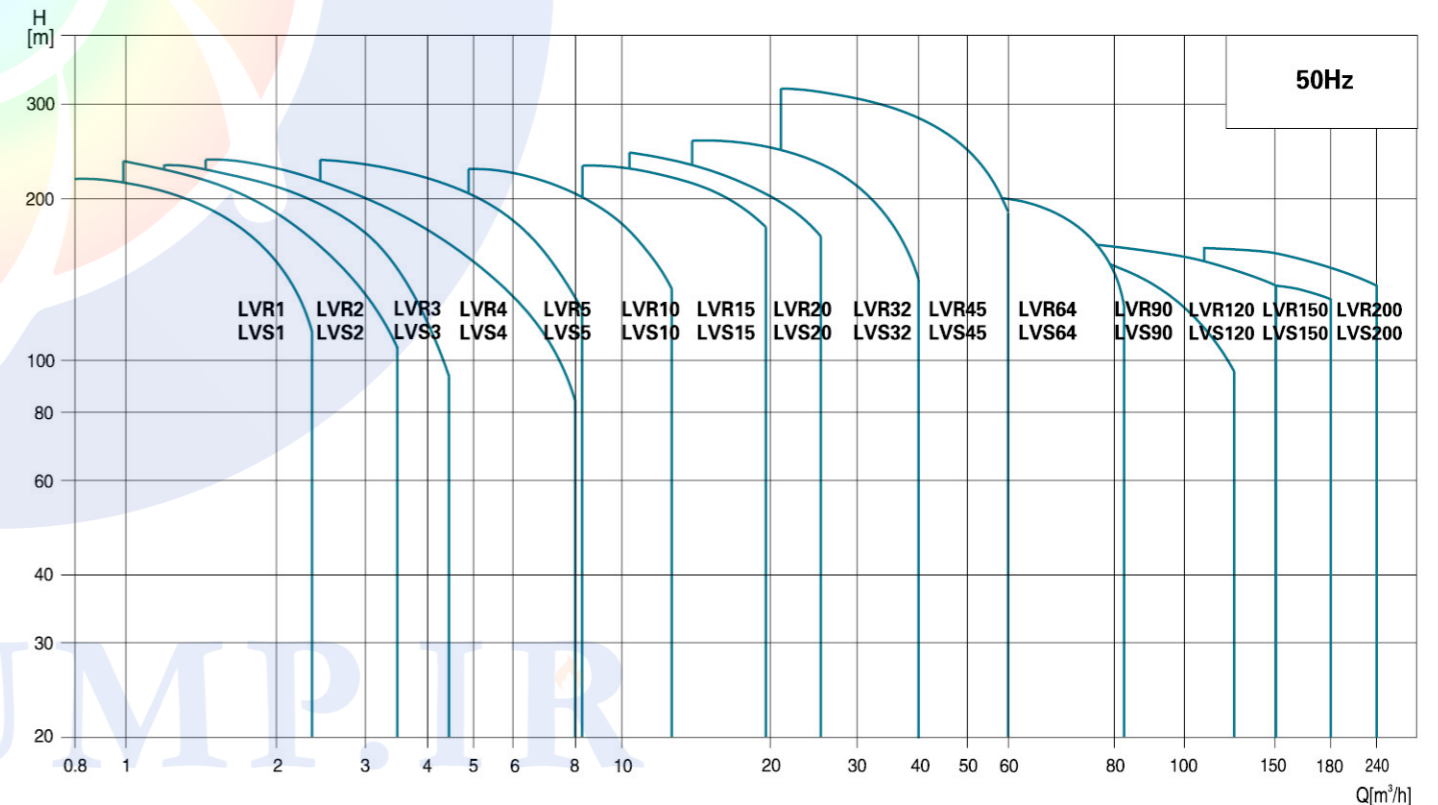

**Hydraulic Performance Curves**

**Dimension Drawing**

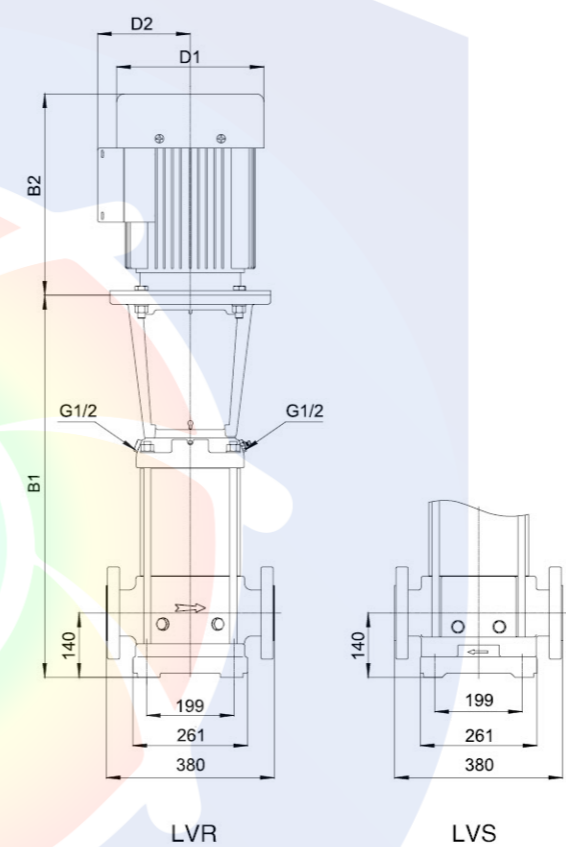
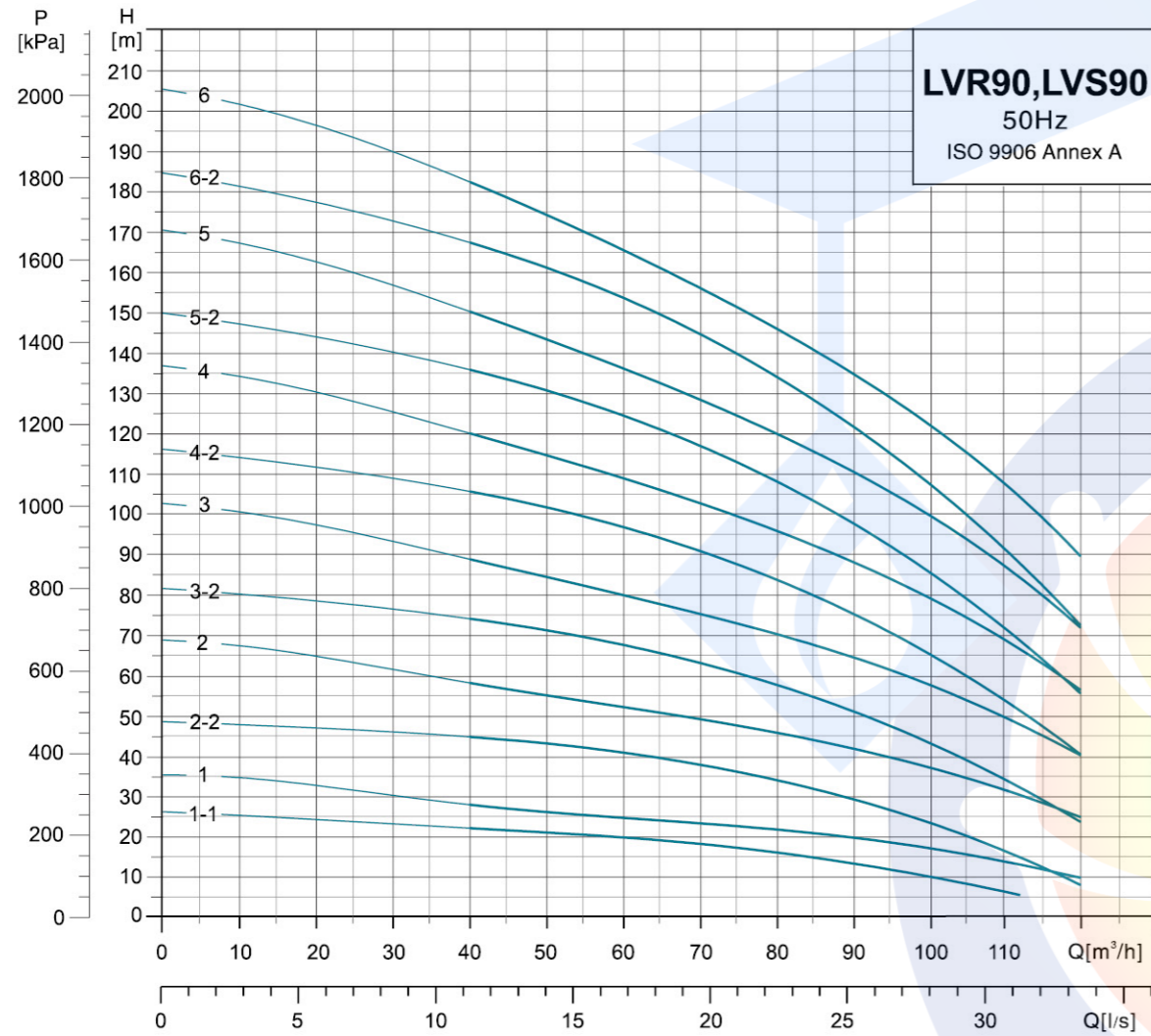

MODEL	DIN FLANGE(LVR, LVS)		D1	D2	N.W. (kgs)
	B1	B1+B2			
90-1-1	572.5	969.5	210	142	116
90-1	572.5	969.5	210	142	121.2
90-2-2	774.5	1273.5	254	175	162.2
90-2	774.5	1273.5	254	175	174.9
90-3-2	866.5	1426.5	330	250	228
90-3	866.5	1466.5	380	280	264
90-4-2	958.5	1638.5	420	305	326
90-4	958.5	1638.5	420	305	326
90-5-2	1051	1731	420	305	354
90-5	1051	1731	420	305	354
90-6-2	1143	1858	470	335	415
90-6	1143	1858	470	335	415

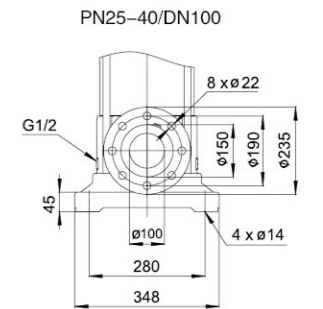
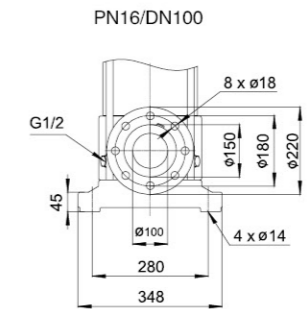

LVR(S)90-1-1~  
LVR(S)90-5

LVR(S)90-6-2~  
LVR(S)90-6

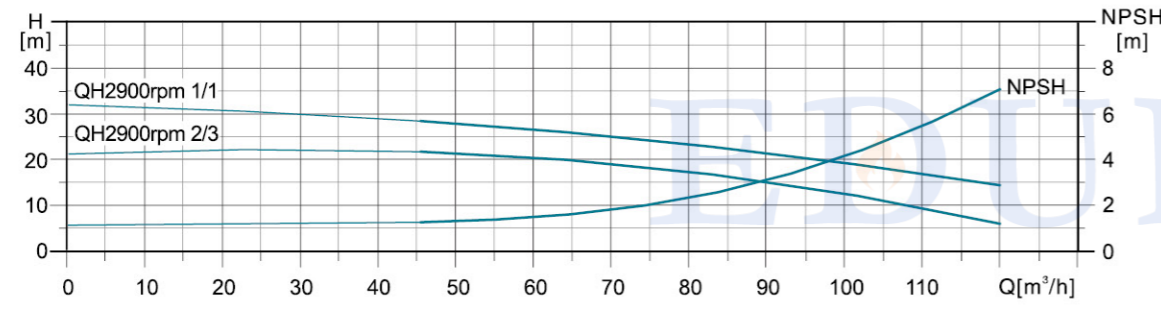
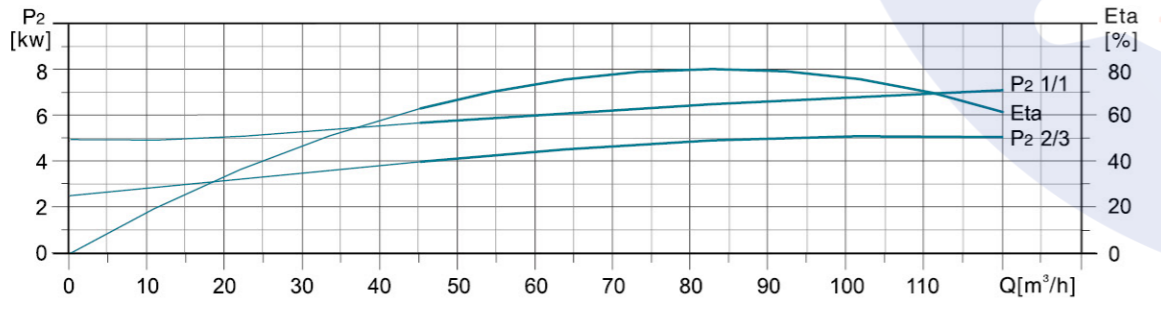

MODEL	POWER[kW]	Q[m³/h]	40	50	60	70	80	90	100	110	120
LVR(S)90-1-1	5.5		22	21	20	18	16	14	10.5	6.5	-
LVR(S)90-1	7.5		38	26	25	23.5	22	20	17.5	14	10
LVR(S)90-2-2	11		45	43	41	38	34.5	30	24	17	8
LVR(S)90-2	15		58	55	52	49	46	42.5	37.5	31.5	25
LVR(S)90-3-2	18.5		74	71.5	68	63.5	58	51.5	44	35	24
LVR(S)90-3	22		88	84.5	80	75.5	70.5	65	58.5	50.5	40
LVR(S)90-4-2	30		106	102	97	91	84.5	76	65.5	54	40
LVR(S)90-4	30		120	114	109	103	96	88.5	79.5	69.5	57
LVR(S)90-5-2	37		136	131	125	118	109	98.5	86.5	72	55
LVR(S)90-5	37		150	144	136	129	121	111	101	87	72
LVR(S)90-6-2	45		166	161	154	145	135	123	108	91.5	72
LVR(S)90-6	45		182	175	166	156	146	135	123	108	90



**EDUPUMP**  
WWW.EDUPUMP.IR

## اولین و بزرگترین

سایت تخصصی سیستم‌های پمپاژ  
با امکان محاسبه آنلاین و انتخاب پمپ

## تولید بوستر پمپ آتش نشانی

در کلاس‌های S3 - S2 - S1  
مورد تایید سازمان آتش نشانی تهران



اولین و بزرگترین مرجع انتخاب آنلاین سیستم‌های پمپاژ

انتخاب آنلاین انواع بوستر پمپ

انتخاب آنلاین انواع پمپ

ارائه مطالب تخصصی

## اولین سایت مرجع

## انتخاب آنلاین پمپ

در حوزه‌های:

ایمنی و آتش نشانی  
آب و فاضلاب  
صنایع غذایی  
استخر  
صنعت  
معدن



## تولید بوستر پمپ

## آبرسانی دور متغیر

بدون محدودیت برند



## آموزش

تهویه و تخلیه دود  
سیستم‌های پمپاژ  
ایمنی معماری  
اطفاء حریق  
اعلام حریق

## مشاوره - طراحی - اجراء

تاسیسات مکانیکی (موتورخانه - استخر)  
تهویه و تخلیه دود  
سیستم‌های پمپاژ  
ایمنی معماری  
اعلام حریق  
اطفاء حریق

تهران، سعدی شمالی، خیابان مرادی نور، پلاک ۳۱

تلفن: ۰۲۱-۷۷۶۸۶۹۶۶ فکس: ۰۲۱-۷۷۶۷۸۶۵۹

EDUPUMP.IR

WWW.EDUPUMP.IR