

APPLICATIONS

- LVR(S) series, vertical multistage centrifugal pump, is suitable for transferring liquids of low viscosity, non-inflammable and non-explosive, not containing solid particles or fibers.
- Water supply: water supply & drainage for high-rise buildings, filtration and transfer at waterworks, pressure boosting in main pipe
 - Industry: Washing and cleaning systems, boiler feeding, cooling water circulation, water treatment systems, auxiliary system, support equipment
 - Water treatment: ultra-filtration systems, reverse-osmosis systems, distillation systems, separators, swimming pools
 - Agricultural irrigation: sprinkler irrigation, drip-feed irrigation
 - Food & beverage industry
 - Fire-fighting system

FEATURES

- Compact, nice appearance, efficient, low noise, reliable seal, easy to use and maintain

OPERATING CONDITIONS

Low viscosity, non-inflammable and non-explosive liquids not containing solid particles or fibers. The liquids must not chemically attack the pump materials. When pumping liquids with a density or viscosity is higher than that of water, a motor with a higher output power rating shall be used.

- Liquid temperature: -15°C+120°C
- Flow ranges: 0.7-85m³/h
- pH: 3~9
- Max. ambient temperature: +40°C
- Max. operation pressure: 33bar
- Altitude: up to 1000m

MOTOR

- Totally enclosed & fan-cooled motor
- Protection class: IP 55
- Standard voltage: 50Hz 1 x 220V/3 x 380V

IDENTIFICATION CODES

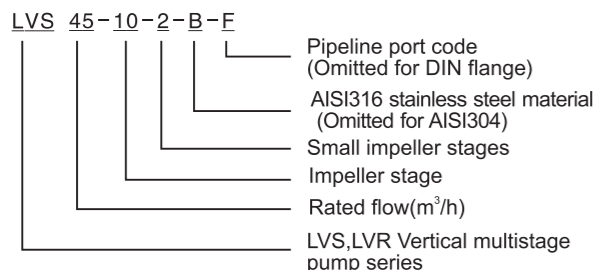

LVS: Stainless steel wetted parts
LVR: Cast iron base & pump cover

Identifications codes of flange structure

F: DIN flange ; A: Oval flange
K: Clamp connector ; G: Threaded connector

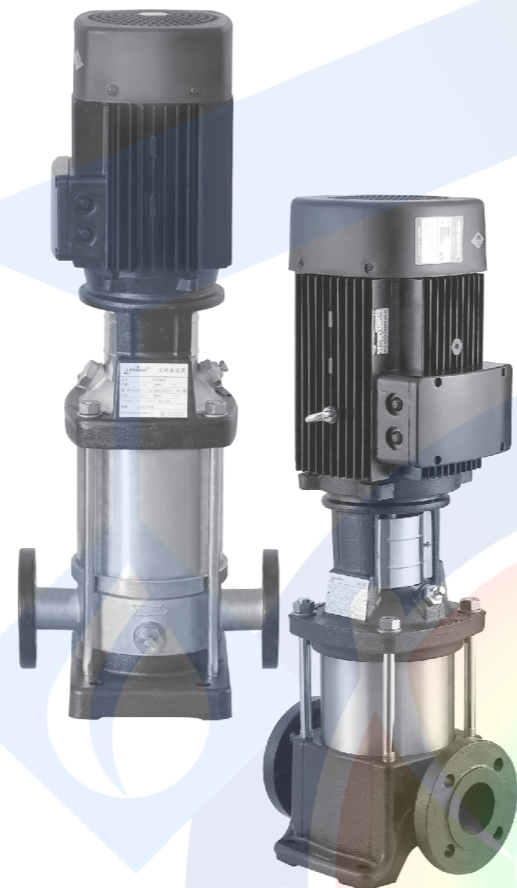

000003

AMBIENT TEMPERATURE

Max. ambient temperature: +40°C. Ambient temperature above 40 or installation at altitude of more than 1000 meters above sea level require the use of an oversize motor. Because of low air density and poor cooling effects, the motor output power P₂ will be decreased. See the picture.

In such cases, it may be necessary to use a motor with a higher output power rating.

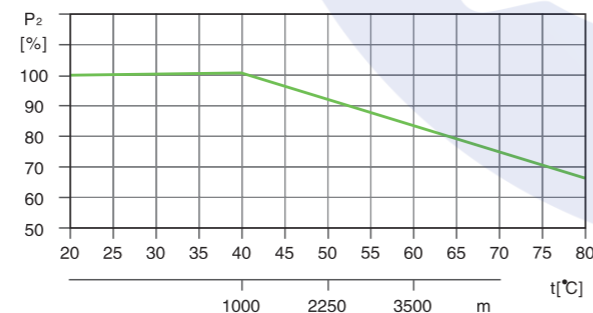

For example, when the pump is installed at altitude of more than 3500 meters above sea level, P₂ will be decreased to 88%. When the ambient temperature is 70°C, P₂ will be decreased to 78%.

MINIMUM INLET PRESSURE-NPSH

Calculation of the inlet pressure "H" is recommended in these situations:

- The liquid temperature is high.
- The flow is significantly higher than the rated flow.
- Water is drawn from depths.
- Water is drawn through long pipes.
- Inlet conditions are poor.

To avoid cavitation, make sure that there is a minimum pressure on the suction side of the pump. The maximum suction lift "H" in meters head can be calculated as follows:

$$H = P_b \times 10.2 - NPSH - H_f - H_v - H_s$$

P_b = Barometric pressure in bar. (Barometric pressure can be set to 1 bar). In closed systems, P_b indicates the system pressure in bar.

NPSH = Net Positive Suction Head in meters head. (To be read from the NPSH curve at the highest flow the pump will be delivering.)

H_f = Friction loss in suction pipe in meters head. (At the highest flow the pump will be delivering.)

H_v = Vapor pressure in meters head. (To be read from the vapor pressure scale. "H_v" depends on the liquid temperature "tm")

H_s = Safety margin=minimum 0.5 meters head.

If the "H" calculated is positive, the pump can operate at a suction lift of maximum "H" meters head.

If the "H" calculated is negative, an inlet pressure of minimum "H" meters head is required.

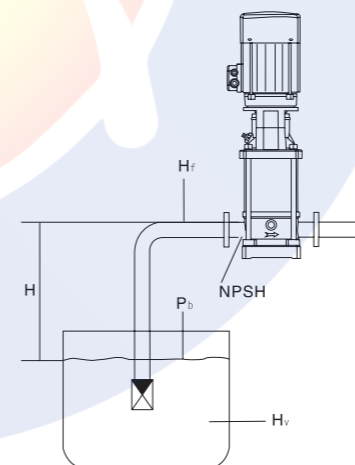

Note: To avoid cavitation, never select a pump with a duty point too far to the right on the NPSH curve. Always check the NPSH value of the pump at the highest possible flow.

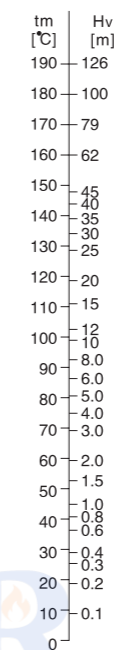

MAXIMUM INLET PRESSURE

The following table shows the maximum permissible inlet pressure. However, the current inlet pressure + the pressure against a closed valve must always be lower than the Max. permissible operating pressure.

If the maximum permissible operating pressure is exceeded, the bearing in the motor may be damaged and the life of the shaft seal reduced.

Pump Type	Maximum Inlet Pressure [bar]
LVR1,LVS1	
1-2 — 1-36	10
LVR2,LVS2	
2-2	6
2-3 — 2-11	10
2-13 — 2-26	15
LVR3,LVS3	
3-2 — 3-29	10
3-31 — 3-26	15
LVR4,LVS4	
4-2	6
4-3 — 4-10	10
4-12 — 4-22	15
LVR5,LVS5	
5-2 — 5-16	10
5-18 — 5-29	15
LVR10,LVS10	
10-1 — 10-6	8
10-7 — 10-22	10
LVR15,LVS15	
15-1 — 15-3	8
15-4 — 15-17	10
LVR20,LVS20	
20-1 — 20-3	8
20-4 — 20-17	10
LVR32,LVS32	
32-1-1 — 32-4	4
32-5-2 — 32-10	10
32-11 — 32-14	15
LVR45,LVS45	
45-1-1 — 45-2	4
45-3-2 — 45-5	10
45-6-2 — 45-13-2	15
LVR64,LVS64	
64-1-1 — 64-2-2	4
64-2-1 — 64-4-2	10
64-4-1 — 64-8-1	15

HOW TO READ THE CURVE CHARTS

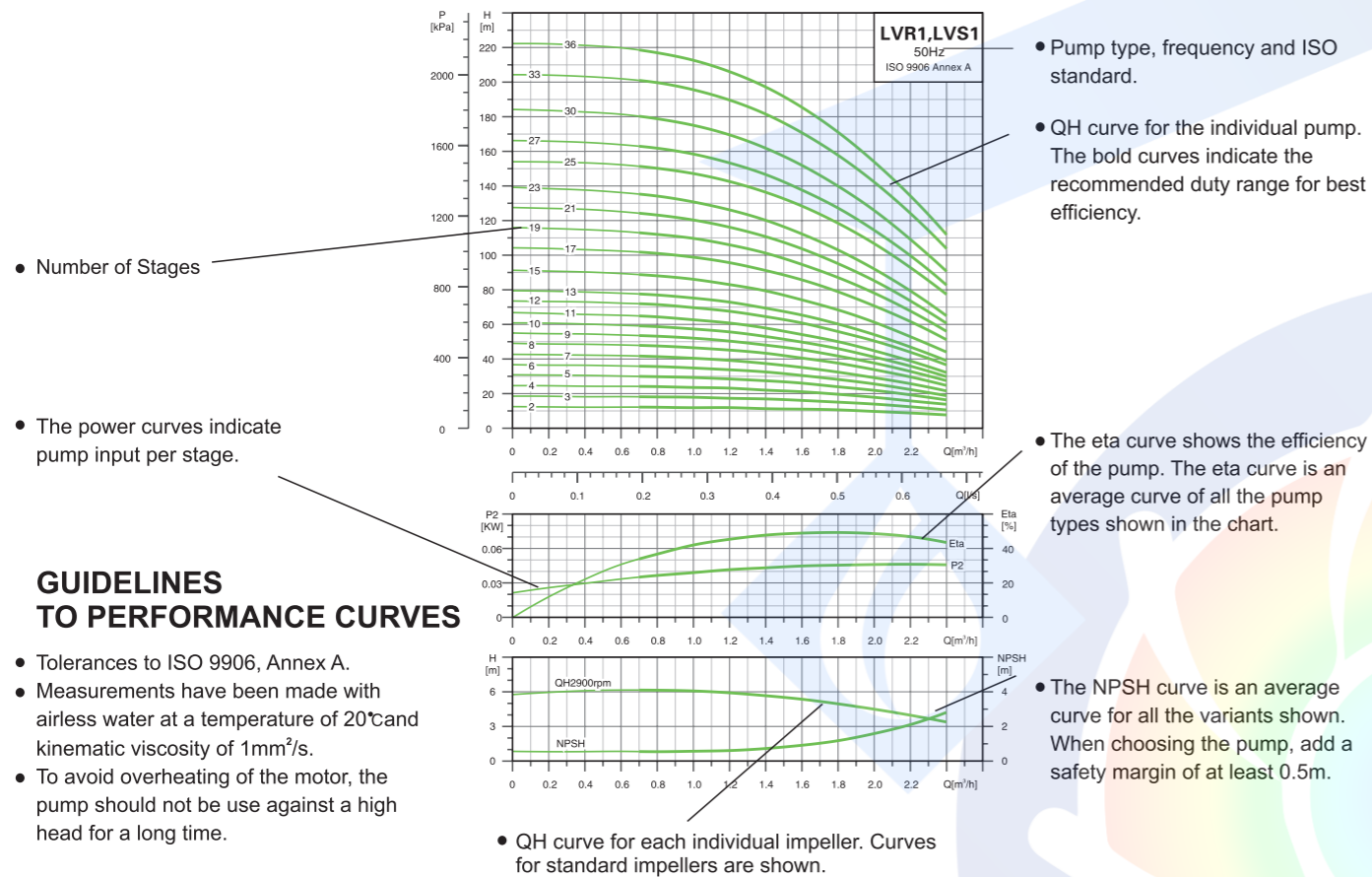

GUIDELINES TO PERFORMANCE CURVES

- Tolerances to ISO 9906, Annex A.
- Measurements have been made with airless water at a temperature of 20°C and kinematic viscosity of 1mm²/s.
- To avoid overheating of the motor, the pump should not be use against a high head for a long time.

MINIMUM FLOW RATE

Due to the risk of overheating, the pump should not be used at a flow below the minimum flow rate. The curve below shows the minimum flow rate as a percentage of the nominal flow rate in relation to the liquid temperature.

Air cooling apparatus

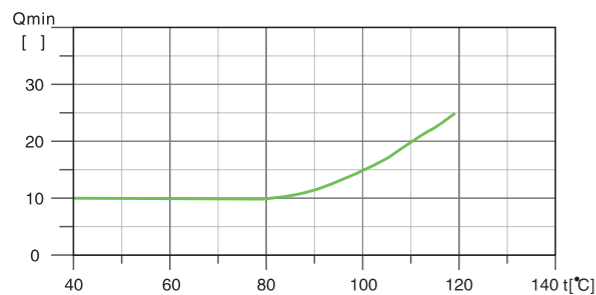

Note: The outlet valve must be opened when the pump is in operation.

TERMINAL BOX POSITIONS
(Note: set to position 1 before delivery)

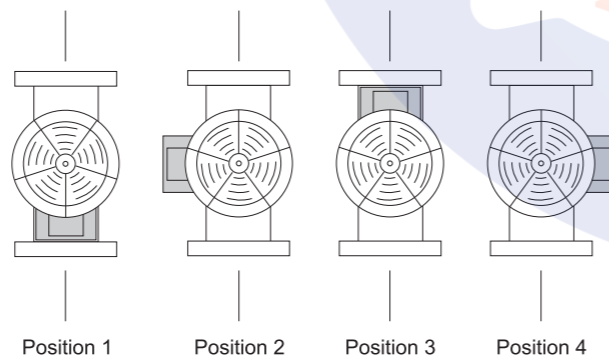

PRODUCT RANGE

MODEL	LVR(S)1	LVR(S)2	LVR(S)3	LVR(S)4	LVR(S)5	LVR(S)10	LVR(S)15	LVR(S)20	LVR(S)32	LVR(S)45	LVR(S)64
DESCRIPTION											
Rated flow [m ³ /h]	1	2	3	4	5	10	15	20	32	45	64
Flow range [m ³ /h]	0.7–2.4	1.0–3.5	1.2–4.5	1.5–8	2.5–8.5	5–13	8–23	10.5–29	15–40	22–58	30–85
Max. pressure [bar]	22	23	24	21	24	22	23	25	28	33	22
Motor power [kW]	0.37–2.2	0.37–3	0.37–3	0.37–4	0.37–4	0.37–7.5	1.1–15	1.1–18.5	1.5–30	3–45	4–45
Temperature Range [°C]	–20°C~+120°C (Note: Both the Max. permissible pressure and liquid temperature range refer to the pump capacity.)										
Max. pump efficiency [%]	45	46	55	59	60	65	70	72	78	79	80
Pipe connection-LVR											
Oval flange	G1	G1	G1	G1 1/4	G1 1/4	–	–	–	–	–	–
DIN flange	–	–	–	–	–	DN 42	DN 50	DN 50	DN 65	DN 80	DN 100
Flange structure	○	○	○	○	○	○	○	○	●	●	●
Pipe connection-LVS											
Oval flange	–	–	–	–	–	–	–	–	–	–	–
DIN flange	DN 32	DN 32	DN 32	DN 32	DN 32	DN 42	DN 50	DN 50	DN 65	DN 80	DN 100
Clamp connector	φ42	φ42	φ42	φ42	φ42	–	–	–	–	–	–
Threaded connector	G1 1/4	G1 1/4	G1 1/4	G1 1/4	G1 1/4	–	–	–	–	–	–
Flange structure	●	●	●	●	●	●	●	●	●	●	●

Note: ○ It means stationary flange structure, ● It means dynamic flange structure

SCOPE OF PERFORMANCE-LVR, LVS

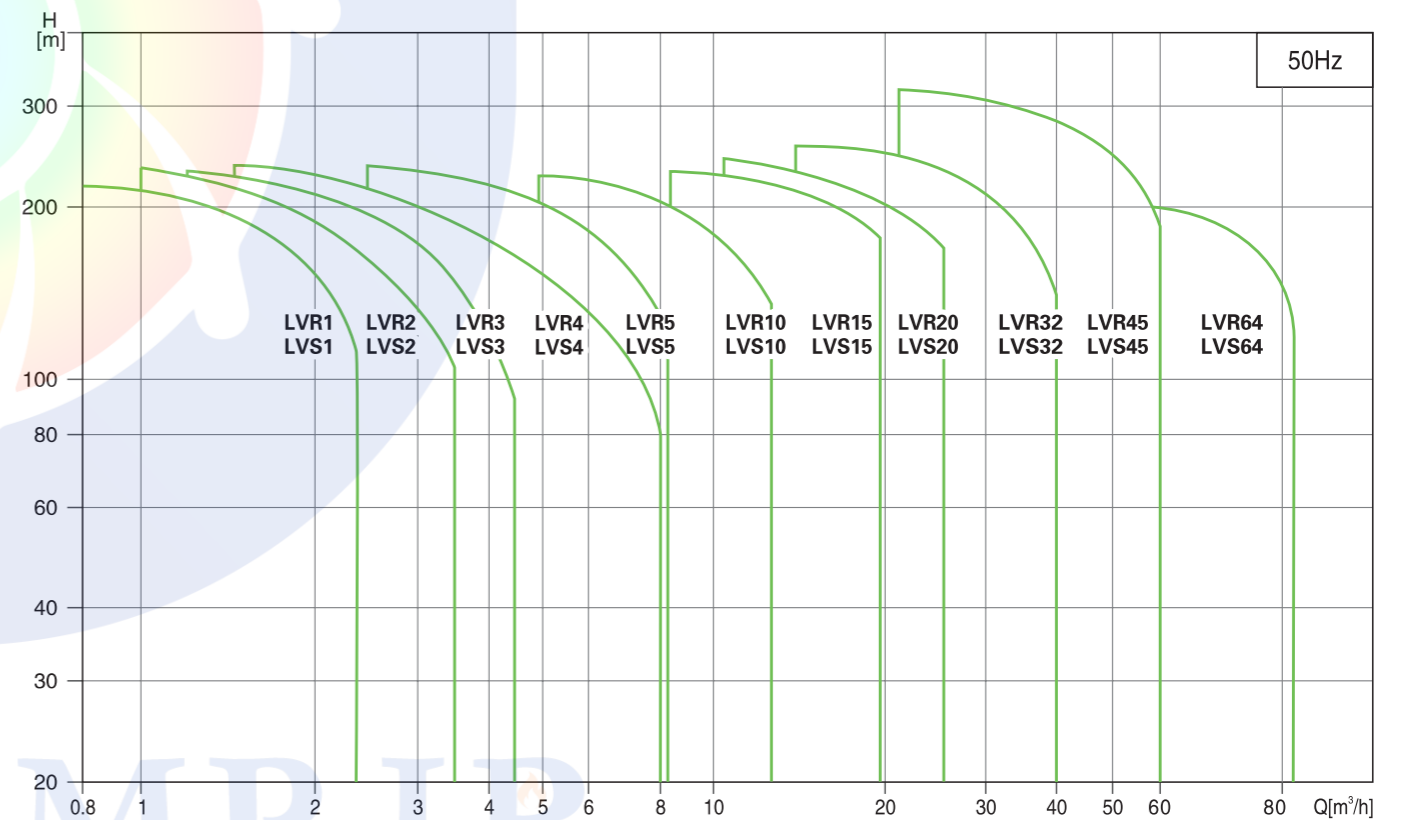

EDUPUMP.IR

CROSS SECTION

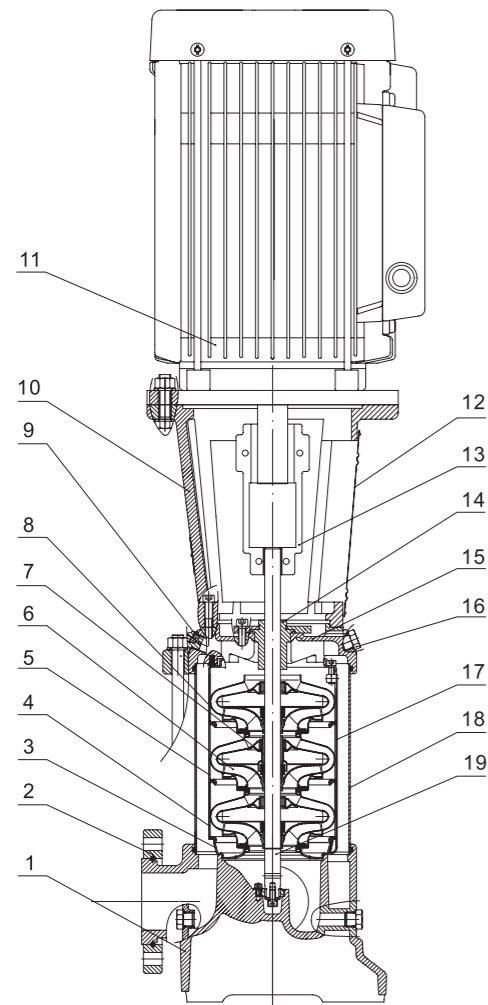

MODEL: LVR32(45,64)

Part	Material	
1	Base	HT200
2	Drainage plug assembly	ZG35
3	Primary diffuser	AISI304
4	Medium diffuser	AISI304
5	Diffuser with bearing	AISI304
6	Impeller	AISI304
7	Actuator	
8	Final diffuser	AISI304
9	Vent plug assembly	AISI304
10	Motor base	HT200
11	Motor	
12	Guarding plate	AISI304
13	Coupling	QT400
14	Catridge seal	
15	Pump cover	ZG304
16	Filling plug	AISI304
17	Tension plate	AISI304
18	Pump barrel	AISI304
19	Pump shaft	AISI304

000003

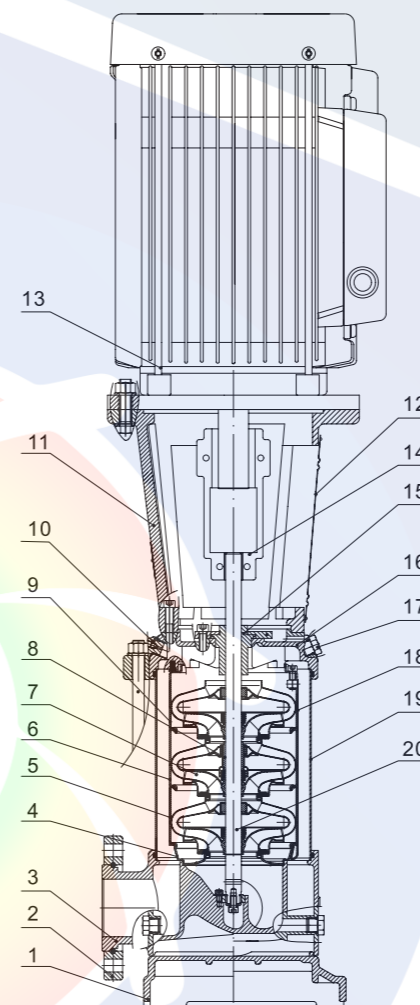

MODEL: LVS32(45,64)

Part	Material	Optional Material	
1	Base plate	HT200	
2	Flange	ZG35	
3	Chasis	ZG304	ZG316
4	Primary diffuser	AISI304	AISI316
5	Medium diffuser	AISI304	AISI316
6	Diffuser with bearing	AISI304	AISI316
7	Impeller	AISI304	AISI316
8	Actuator		
9	Final diffuser	AISI304	AISI316
10	Vent plug assembly	AISI304	AISI316
11	Motor base	HT200	
12	Motor		
13	Guarding plate	AISI304	
14	Coupling	QT400	
15	Catridge seal		
16	Pump cover	ZG304	ZG316
17	Filling plug	AISI304	AISI316
18	Tension plate	AISI304	AISI316
19	Pump barrel	AISI304	AISI316
20	Pump shaft	AISI304	AISI316

EDUPUMP.IR

HYDRAULIC PERFORMANCE CURVES

DIMENSION DRAWING

MODEL	DIN FLANGE(LVR, LVS)		D1	D2
	B1	B1+B2		
45-1-1	559	894	198	120
45-1	559	931	220	134
45-2-2	639	1030	220	134
45-2	639	1030	220	134
45-3-2	829	1327	334	263
45-3	829	1327	334	263
45-4-2	909	1407	334	263
45-4	909	1407	334	263
45-5-2	989	1487	334	263
45-5	989	1487	334	263
45-6-2	1069	1631	382	305
45-6	1069	1631	382	305
45-7-2	1149	1809	420	372
45-7	1149	1809	420	372
45-8-2	1229	1889	420	372
45-8	1229	1889	420	372
45-9-2	1309	1969	420	372
45-9	1309	1969	420	372
45-10-2	1389	2049	420	372
45-10	1389	2049	420	372
45-11-2	1469	2145	458	427
45-11	1469	2145	458	427
45-12-2	1549	2225	458	427
45-12	1549	2225	458	427
45-13-2	1629	2305	458	427

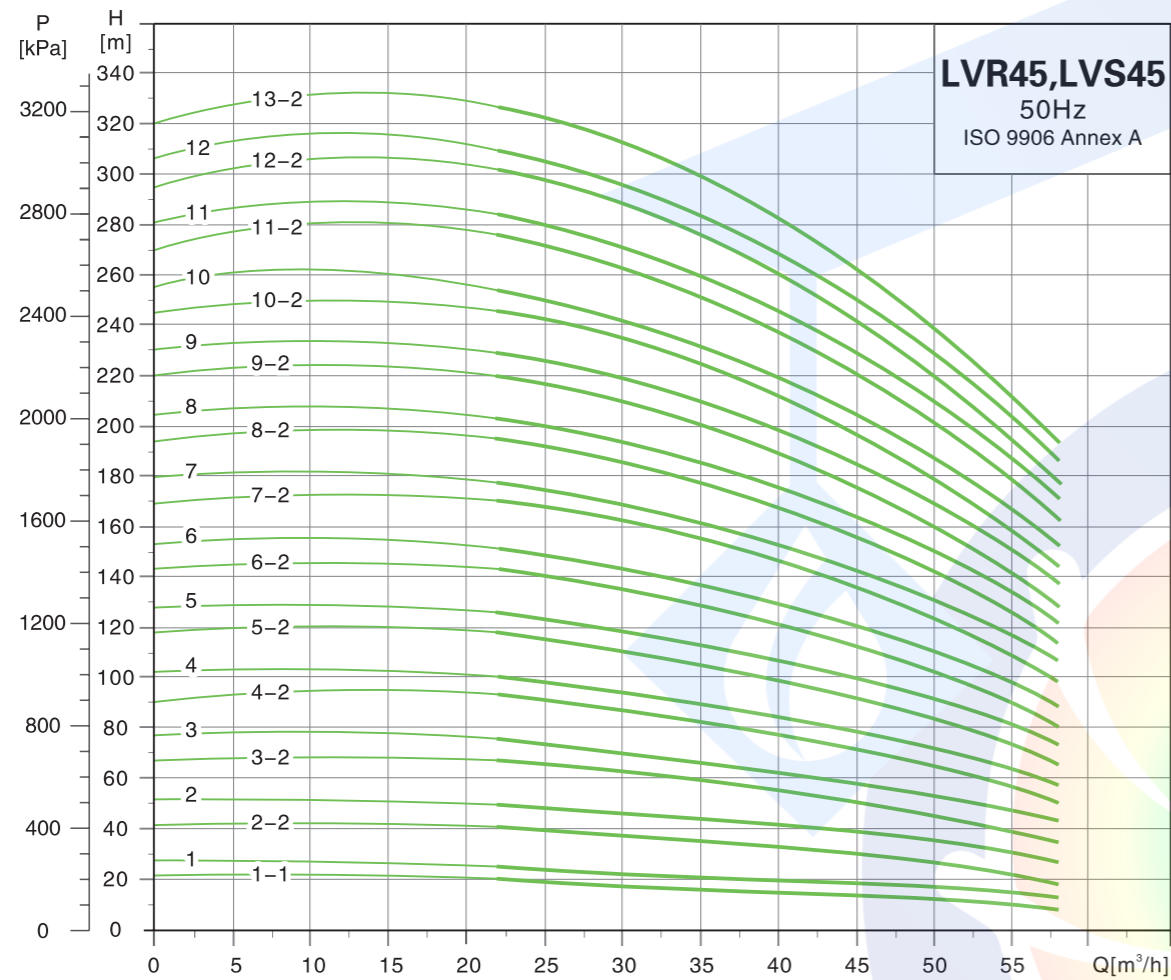

000003

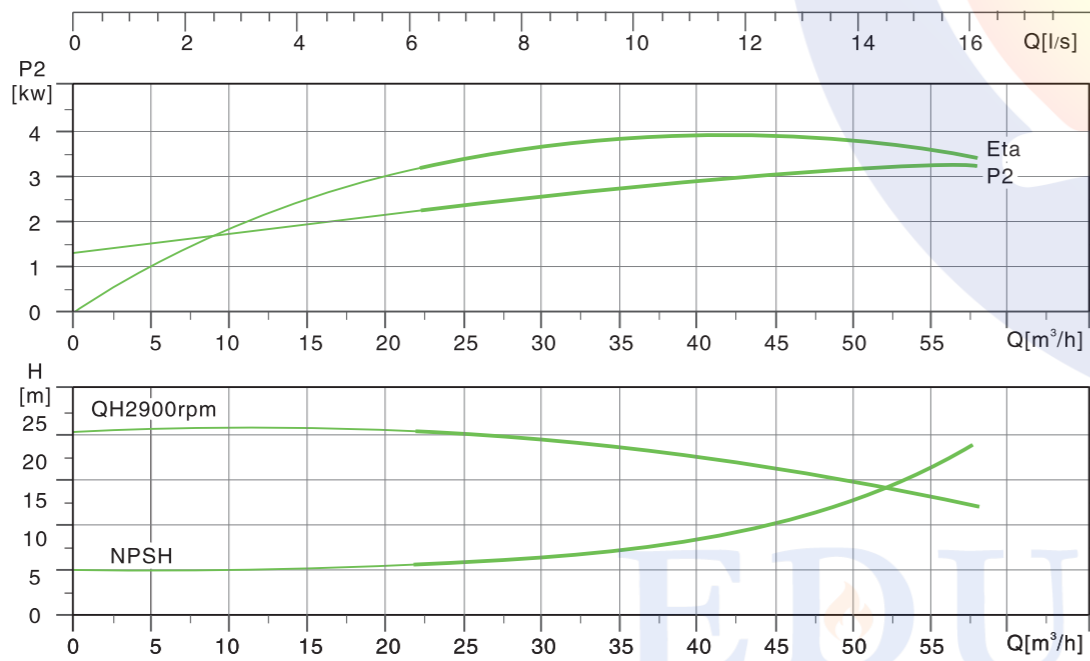
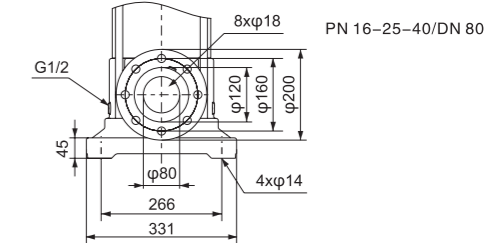
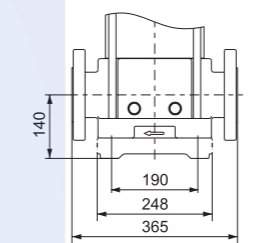
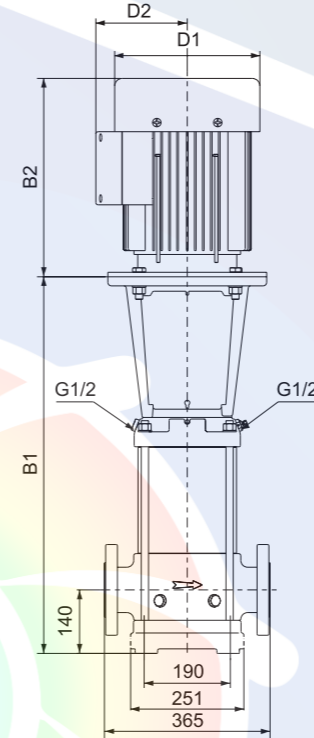

MODEL	POWER[kW]	Q[m³/h]	25	30	35	40	45	50	55
45-1-1	3		20	19.5	18	17	14.5	12.5	10.5
45-1	4		24	23	22	20.5	19	17.5	15
45-2-2	5.5		41	39	37	34	30.5	26.5	22
45-2	7.5		48.5	46.5	44.5	42	39	35	31
45-3-2	11		66	64	61	56.5	52	46	40
45-3	11		73.5	71	68	64	59.5	54	47.5
45-4-2	15		91	88	84	78.5	72	64.5	56
45-4	15		98.5	95	91	85.5	79.5	72.5	64
45-5-2	18.5		116	113	107	101	92.5	83.5	73
45-5	18.5		124	120	115	108	100	91.5	81
45-6-2	22		142	137	131	122	113	103	90
45-6	22		149	144	138	130	121	111	98
45-7-2	30		168	163	156	147	135	123	109
45-7	30		176	171	163	155	144	132	116
45-8-2	30		193	187	179	168	155	142	126
45-8	30		200	194	187	176	164	149	134
45-9-2	30		217	211	202	189	175	159	142
45-9	30		226	219	210	199	185	170	151
45-10-2	37		243	236	225	212	196	179	159
45-10	37		251	243	233	220	205	187	166
45-11-2	45		273	264	253	238	222	201	179
45-11	45		281	272	261	246	230	209	187
45-12-2	45		298	289	276	261	242	220	195
45-12	45		306	296	284	268	251	229	204
45-13-2	45		323	313	300	283	263	239	212



EDUPUMP
WWW.EDUPUMP.IR

اولین و بزرگترین

سایت تخصصی سیستم‌های پمپاژ
با امکان محاسبه آنلاین و انتخاب پمپ

تولید بوستر پمپ آتش نشانی

در کلاس‌های S3 - S2 - S1
مورد تایید سازمان آتش نشانی تهران



اولین و بزرگترین مرجع انتخاب آنلاین سیستم‌های پمپاژ

انتخاب آنلاین انواع بوستر پمپ

انتخاب آنلاین انواع پمپ

ارائه مطالب تخصصی

اولین سایت مرجع

انتخاب آنلاین پمپ

در حوزه‌های:

ایمنی و آتش نشانی
آب و فاضلاب
صنایع غذایی
استخر
صنعت
معدن

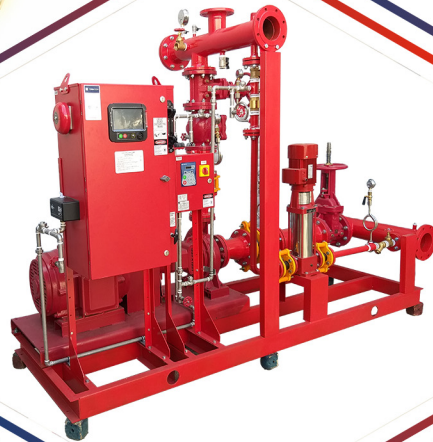

تولید بوستر پمپ

آبرسانی دور متغیر

بدون محدودیت برند



آموزش

تهویه و تخلیه دود
سیستم‌های پمپاژ
ایمنی معماری
اطفاء حریق
اعلام حریق

مشاوره - طراحی - اجراء

تاسیسات مکانیکی (موتورخانه - استخر)
تهویه و تخلیه دود
سیستم‌های پمپاژ
ایمنی معماری
اعلام حریق
اطفاء حریق

تهران، سعدی شمالی، خیابان مرادی نور، پلاک ۳۱

تلفن: ۰۲۱-۷۷۶۸۶۹۶۶ فکس: ۰۲۱-۷۷۶۷۸۶۵۹

EDUPUMP.IR

WWW.EDUPUMP.IR